

GM9907-LB

User's Manual

110608070001

V01.01.03

©2020, Shenzhen General Measure Technology Co., Ltd. All rights reserved.

Without Shenzhen General Measure Technology Co., Ltd.'s permission, any company or person have no responsibility to copy, transmit, transcribe or translate to any language version.

Our company's products are under continually improvement and updating so we reserved the right to modify this manual at any time without notice. For this reason, please visit our website regularly to update newest information.

Company Website [http:// www.gmweighing.com](http://www.gmweighing.com)

Product Performance Standards: GB / T 7724-2008



Contents

1.	Outline.....	- 1 -
	1.1 Functions and Features.....	- 1 -
	1.2 Front Panel Description.....	- 2 -
	1.3 Rear Panel Description.....	- 3 -
	1.4 Technical Specifications.....	- 3 -
	1.4.1 General specifications.....	- 3 -
	1.4.2 Analog part.....	- 3 -
	1.4.3 Digital part.....	- 4 -
2.	Installation.....	- 5 -
	2.1 General principle.....	- 5 -
	2.2 Load cell connection.....	- 5 -
	2.3 I/O Function Port Connection.....	- 5 -
	2.4 Power Supply Connection.....	- 6 -
	2.5 Serial Port Connection.....	- 6 -
	2.6 Touch Screen Calibration.....	- 7 -
3.	User Permission Description.....	- 8 -
4.	Menu.....	- 9 -
	4.1 Receipt parameter.....	- 10 -
	4.2 Calibration.....	- 15 -
	4.3 Weighing Parameter.....	- 17 -
	4.4 I/O Module.....	- 18 -
	4.4.1 Output port & input port definition.....	- 18 -
	4.5 Maintenance.....	- 22 -
	4.5.1 Communication Setting.....	- 22 -
	4.5.2 Hardware Test.....	- 23 -
	4.5.3 Factory Reset.....	- 24 -
	4.5.4 Software upgrade.....	- 24 -
	4.5.5 System info.....	- 24 -
	4.6 Statistics.....	- 25 -
5.	Function Description.....	- 26 -
	5.1 Batch.....	- 26 -
	5.2 Batching Process Order function.....	- 26 -
	5.3 ACUM content check and clear.....	- 26 -
	5.4 Manual DICS/DICS allow.....	- 27 -
	5.5 Manual Zeroing.....	- 27 -
	5.6 Power Loss Resume.....	- 27 -
	5.7 Compensation Function.....	- 28 -

5.8 Free Fall Correction.....	- 28 -
5.9 DICS monitoring function.....	- 28 -
5.10 Batch monitoring function.....	- 28 -
5.11 USB disk update software.....	- 29 -
5.11.1 Foreground update process.....	- 29 -
5.11.2 Background update process.....	- 29 -
5.12U disk update boot interface.....	- 29 -
5.13 Peripheral stirring function.....	- 29 -
5.14 Stiring Function(Original Striring Function).....	- 30 -
6. Communication Description.....	- 31 -
6.1 RE protocol	- 31 -
6.1.1 rE-Cont	- 31 -
6.1.2 rE-Read	- 32 -
6.2 RS protocol	- 32 -
6.2.1 rS-Cont	- 33 -
6.2.2 rS-Read	- 34 -
6.3 tt Toledo protocol.....	- 41 -
6.4 Ethernet communication.....	- 42 -
6.5 Printing method.....	- 42 -
6.5.1Auto Print.....	- 43 -
6.5.2 Cumulative print the recipe.....	- 43 -
6.5.3 All Supplement ACUM Print.....	- 44 -
6.6 Modbus-RTU protocol	- 45 -
6.6.1 Function code and abnormal code.....	- 45 -
6.6.2 MODBUS transmission mode.....	- 46 -
6.6.3 MODBUS address assignment.....	- 46 -
7. Auto batching process.....	- 75 -
7.1 Auto batching sequence.....	- 75 -
7.2 Basic process description:	- 75 -
8. Dimension (mm).....	- 76 -

1. Outline

GM9907-LB batching controller is a new batching controller specially developed for the occasion of batching control in industrial field. The controller adopts English touch screen display interface, intuitive and simple operation; The new algorithm makes the weighing control faster and more accurate. USB interface and dual serial port make the device easier to system interconnection. Can be widely used in concrete mixing and asphalt mixture equipment, metallurgical blast furnace, converter and chemical, fill and other occasions need batching control.

1.1 Functions and Features

- Full English display interface, make the operation more intuitive and easy
- 28 I/O Function input and output control (12 in /16 out); input and output port location can be customized.
- I/O test function to convenient batching weighers debugging.
- Jog filling
- 20 recipes can be stored for different weighing capacity
- Convenient USB port to input and output of various types parameters
- Automatic drop correction function
- Multiple digital filtering function
- Batch number setting function
- Automatic zero tracking function
- Time / date function
- Three-level user identity setting
- Dual serial ports to connect with printer, computer, Secondary display.
- Ethernet communication function, can communicate with computer.
- Support 12 batch, each can pause, stir, convenient manual filling and mix stir.
- Batching process can not to show the recipe, which can be used for recipe confidential.
- Can display the dynamic batching process, convenient for users to accurately understand the on-site batching state.

1.2 Front Panel Description

Interface Description:

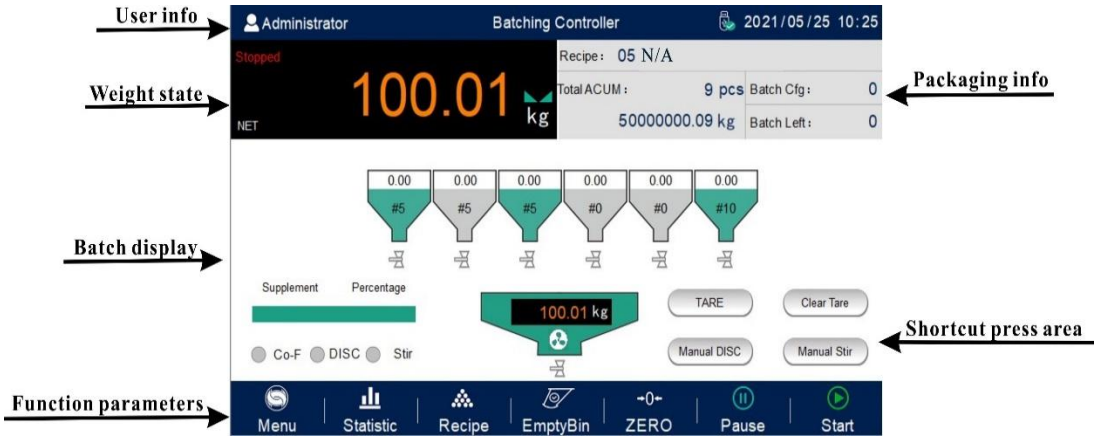

- ① User info: Show user ID, system time.
- ② Weight state: Weight value display, weight unit display.
- ③ Batch display: Can display batch info target value and current weight value, quickly revise batch parameter target value, coarse filling, medium filling etc.
- ④ Function parameters: Controller menu parameter and setting
- ⑤ Packaging info: Show current ACUM info, switch recipe and set batch number quickly, clear the current recipe.
- ⑥ Shortcut press area: Tare, clear tare, manual DISC, manual stir shortcut press.

1.3 Rear Panel Description

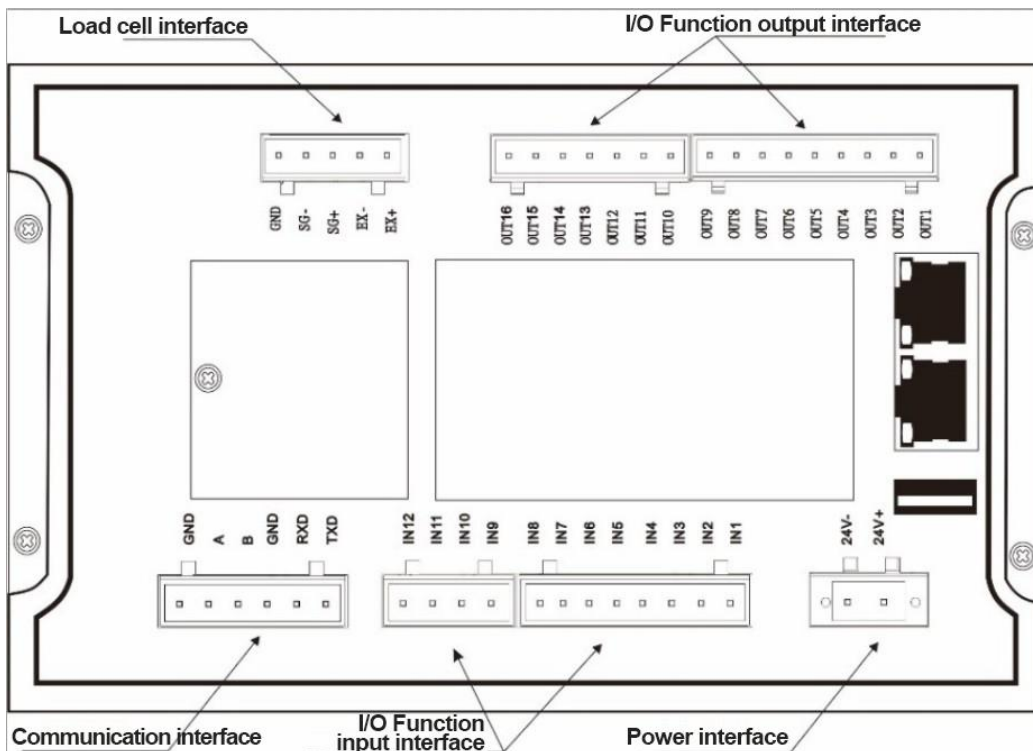

1.4 Technical Specifications

1.4.1 General specifications

- Power supply: **DC24V**
- Power filter: Included
- Operating temperature: **-10 ~ 40 °C**
- Maximum humidity: 90% RH without dew
- Power consumption: about **15W**
- Dimensions: **190mm × 124mm × 48mm**

1.4.2 Analog part

- Load cell power supply: **DC5V 125mA (MAX)**
- Input impedance: **1000Ω**
- Zero adjustment range: **0.002 ~ 15mV (when load cell is 3mV/V)**
- Input sensitivity: **0.02uV/d**
- Input range: **0.02 ~ 15mV**
- Conversion: **Sigma- Delta**

A/D Conversion rate: 120、240、480、960 Times/second

Non-linear: **0.01% F.S**

Gain drift: **10PPM /°C**

The maximum display accuracy: **1/100000**

1.4.3 Digital part

Display: **7 inch** resistance touch screen

Negative display: "—"

Overload Indication: weight over range/low signal of load cell

Decimal point position: 5 options

2. Installation

2.1 General principle

- 1) Make appropriate installation holes on the control box, (size: 179 (± 1) mm \times 113 (± 1) mm)
- 2) Install the GM9907-LB into a control box.
- 3) Remove the fixing plates on both sides of GM9907-LB, fix it with the fixing plates and lock them with M3*10 screws.

2.2 Load cell connection

GM9907-LB batching controller can connect a resistance strain bridge sensor. When chose the six-wired load cells, you must bridge the SN+ with EX+ and bridge the SN- with EX-.

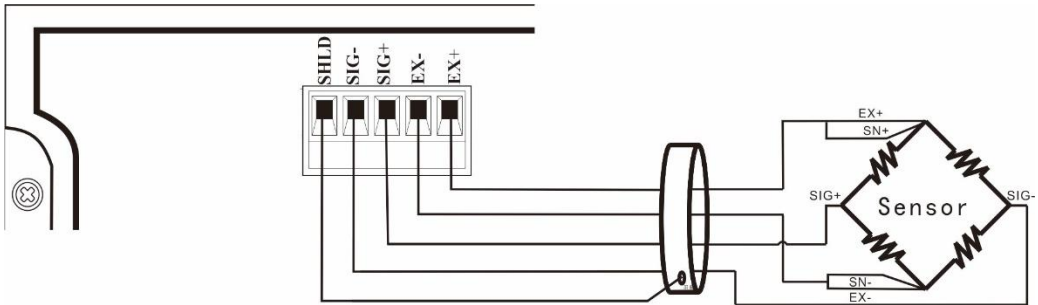

EX+: Excitation+ **EX-:** Excitation- **SN+:** Sense+ **SN-:** Sense- **SIG+:** Signal+ **SIG-:** Signal-

2.3 I/O Function Port Connection

GM9907-LB batching controller controls 28 lines I/O (12 input and 16 output). It uses optoelectronic isolation technology to transfer data. The I/O signal input is low level effective, and the output is open-collector mode. The driving current can reach 500mA and the full load current is up to 3A, and Terminal connection is shown as below:

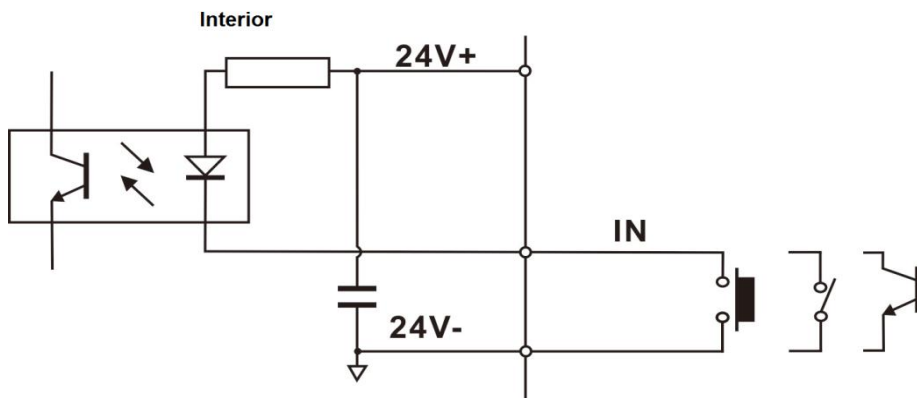

I/O Function Input port diagram

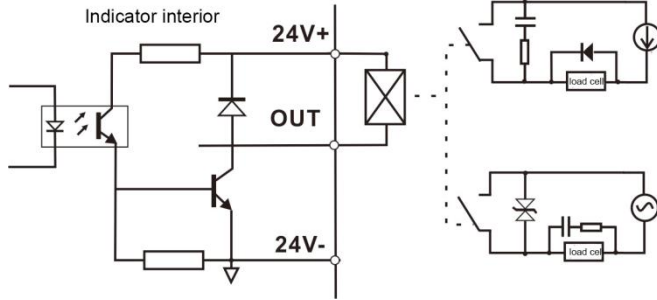

I/O Function output connection diagram

I/O module value of **GM9907** is user-defined to facilitate wiring and some special applications. Please refer to section 4.4 for I/O module.

2.4 Power Supply Connection

GM9907-LB batching controller use 24V DC power supply. The connection is shown in the figure below:

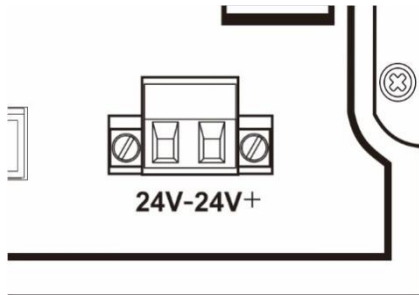

Power terminal diagram

24V+ connect DC+, 24V-connect DC-.

Note: this product use 24V DC power supply, use 220V AC power supply will permanently damage the controller and cause danger.

2.5 Serial Port Connection

GM9907-LB can provide two serial ports. It is depicted below. One for **RS-232** (Port **TXD**、**RXD**、**GND**); the other is **RS-485**, (Port **A**、**B**、**GND**) .serial ports support: **MODBUS** mode, Cont mode, Command Mode ,Toledo Protocol and Print.

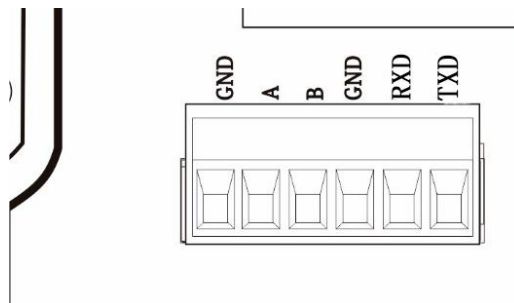

Controller and computer connection diagram:

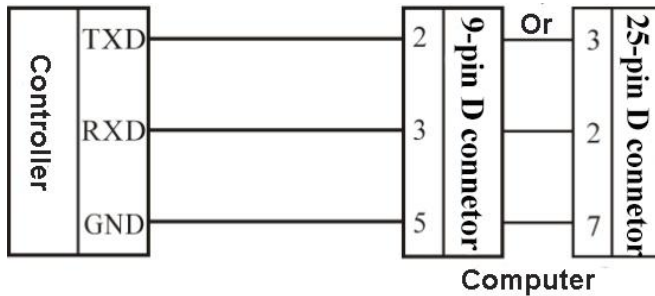

Connection between GM9907-LB and a host computer (RS-232):

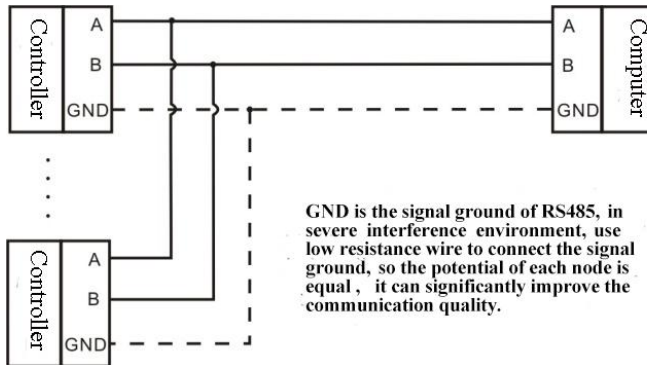

Connection between GM9907-LB and a Host Computer (RS-485)

2.6 Touch Screen Calibration

First use new controller or laid-aside for a long time need to calibrate touch screen, calibrate instruction:

GM9907-LB power on, long press any point on the touch screen at the same time, system turn to touch screen calibrate interface, long press cursor position on touch screen, cursor position calibrate finish, after the interface displays the coordinates of this point, enter to next calibrate automatically. Follow cursor position changes long press accordingly, calibrate finish, and interface show 5 calibration point coordinates, enter to main interface automatically. If enter the calibration interface of the touch screen by mistake, press the "cancel" button in the lower right corner to exit the interface.

3. User Permission Description

In order to prevent wrong operation causing **GM9907-LB** working improperly, it provides three rights (operators, administrators and system administrators): System administrator can perform all operations (not open to users). The operator and administrator rights restrictions are as follows:

Permission	Operation
Operator	Can check all the parameters.
	Can set receipt's target value and coarse, medium, fine and Inhibit Timer, I/O module test, open the power loss resume, change the recipe name, Number of ingredients, tank No.
	Can change the recipe and set batch No. in main interface.
Administrator	All operator privileges are available.
	Can set over/under value, Continuous filling, Free Fall correction, Compensation, JogFlow ON/OFF, calibration, set weight parameters, I/O module define, set system time, and process the history data.

Permission description:

- ◆ Controller default operator log on.
- ◆ Swift permission, can click the parameter item that needs permission, and enter the password of the corresponding administrator (**Password:0000**) or system administrator (**Password:000000**) in the pop-up box to log in successfully.
- ◆ Click the parameter item that needs permission, and the current user's password can be modified in the pop-up box.
- ◆ In the [**System Info.**] parameter of [**Maintenance**], set the permission exit time, which is used to limit the login duration of administrators and system administrators. When the permission exit time reaches, the privileges of the current administrator or system administrator will be returned to the operator privileges.

4. Menu

Click the menu to check or revise parameters. The menu is shown as follows.

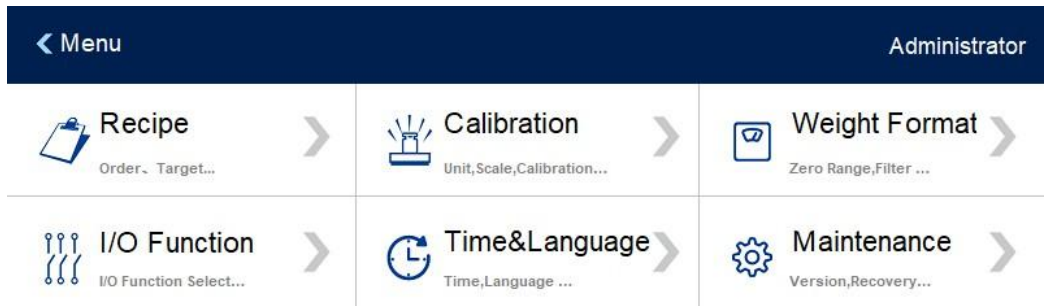

- ◆ Click each parameter item to view and set the home parameter information under the current parameter item.
- ◆ Click top left of interface to exit the current interface and return to the previous page.

	Parameter	Parameter list	Description
Menu	Recipe	Relevant recipe parameters	Choose receipt No., set packing supplement's target value etc parameters.
			Set Process sequence
			Set receipt's all supplement common relevant parameters.
	Calibration	Set calibration parameters	Set unit, Division, Decimal Point, Full Scale etc.
			Starts calibration job, used to calibrate controller.
	Weighing parameters	STAB Range, Filter Strength etc	STAB Range, zeroing, Filter Strength etc
	I/O Module	Input definition	Input port definition.
		Output definition	Output port definition.

Time and language	Language setting	Default English, Mandarin and English optional
	Time setting	Screen time setting
Maintenance	Communication	Serial ports, ethernet, print etc setting
	Hardware Test	To test all input and output connection.
	Reset	All parameters reset to factory setting
	Firmware Update	Firmware Update
	System Info.	Set permission exit time,show the target value,check calibration times ,check code and backlight setting.

4.1 Recipe parameter

Click the recipe in the menu interface, and enter the 20 recipe selection interface, which displays the recipe number, recipe name and ingredient order.

- ◆ Click the recipe number button on the right to switch the recipe number.
- ◆ Click on each recipe bar to enter the corresponding recipe interface.
- ◆ Click the upper left to return to the upper interface.
- ◆ In the receipt interface, can set the process sequence, set the receipt name, set the total number of ingredients, and reset the order of ingredients. As shown in the figure below.

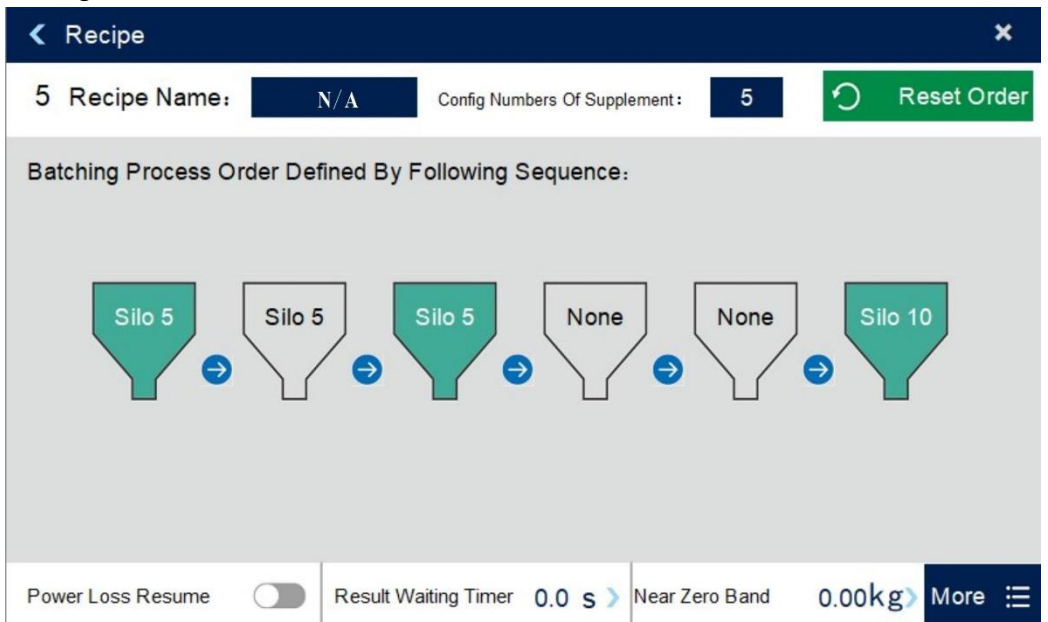

The controller can be configured with 12 kinds of supplements, and corresponding formula parameters should be set for each supplement.

- ◆ What is the total number of ingredients set? The corresponding kinds of ingredients should be set. Otherwise, the prompt message "Silos Used NOT Match Recipe" will appear.

Receipt parameters show as below:

Item parameter	Description
Used to set parameters related to packing weight value (single silo parameter setting) Click on each silo and click [Config] in the material setting box to enter the recipe parameter setting of each material	
1.Target value	Target value. Initial value:0; range: 0~full scale
2. Co-Fi Remain	In quantitative process, if the weighing value \geq target value – Coarse Flow leading quantity, closing Coarse Flow fill. Initial value:0; range: 0~full scale
3. Me-Fi Remain	In quantitative process, if the weighing value \geq target value – Medium Flow leading quantity, closing Medium Flow. Initial value:0; range: 0~full scale
4. Free Fall	In quantitative process, if the weighing value \geq target - free fall value, closing Fine Flow. Initial value:0; range: 0~full scale
5. Over Limit Value	In quantitative process, if the weighing value \geq target + Over Limit Value, judge as over. Initial value:0.5, range: 0~full scale
6. Under Limit Value	In quantitative process, if the weighing value \leq target –Under Limit Value, judge as Under. Initial value:0.5, range: 0~full scale
7. Pause ON/OFF	After batching each supplement, if need pause, ON/OFF optional. Initial value: ON.
8. Filling PreDelay Timer	When starts quantitative process, after this timer, controller starts STAB and zeroing, (if not the PreFill Zero Interval condition is not met, do not starts STAB, do not zeroing), then starts filling process. Initial value:0.5, range: 0~99.9 (Unit :s)
9. COMP. Inhibit Timer(Co-F)	When starts quantitative process, within this timer, to avoid overshooting without weight judgment, coarse filling has been effective. Initial value:0.5, range: 0~99.9 (Unit :s)
10. COMP. Inhibit Timer(Me-F)	After the end of coarse filling, in this period of time, in order to avoid overshooting without weight judgment, Medium filling has been effective. Initial value:0.5, range: 0~99.9 (Unit :s)
11. COMP. Inhibit	After the end of the Medium filling, in this period of time, in order to

Timer(Fi-F)	avoid overshoot without weight judgment, fine filling has been effective. Initial value:0.5, range: 0~99.9 (Unit :s)
12. Stir Control	Whether the supplement needs to be stirred after filling Initial value: OFF; Stir After Fill, Stir When Fill. (Note: when in Stir After Fill and Stir When Fill below parameters exist)
13. Stir PreDelay	Initial value:0.5, range: 0~99.9 (Unit :s)
14. Delay After Stir	Initial value:0.5, range: 0~99.9 (Unit :s)
15. Stir Time	Initial value:0.5, range: 0~99.9 (Unit :s) (Note: After filling starts stir ,this parameter exist)
[Receipt] parameter , set Power Loss Resume,Result Waiting Timer and Near Zero Band parameters.	
1. Power Loss Resume	ON/OFF optional.Initial value:OFF.When turn on,when controller runs appears power loss resume, when return on, pop-up box, after confirm can return to power loss resume working condition.
2. Result Waiting Timer	After the end of the filling of the last kind of supplement, after a delay, the over and under alarm is output. Start to the next material filling predelay timer, if there is no alarm. If it is the last kind of supplement, start unloading.Initial value:0.5, range: 0~99.9 (Unit :s)
3. Near Zero Band	In quantitative process, if weight value \leq Near Zero Band , Starts DISC Delay Timer. Initial value:0; range: 0~full scale
[More]-[Page 1] interface parameter, set batching process timer parameter	
1. Continuous Batching ON/OFF	Initial value: OFF; Optional: OFF: After finishing the supplement, stop and wait for it to start again; On: The batching stops after completing the whole batch
2. Fill Speed Control	Initial value: 0: COMB Option: 0: COMB; Co-F ABC output, Me-F BC output, Fi-F C output (3 control line); 1: Sequence filling: Co-F A output, Me-F B output, Fi-F C output (3 control line); 2: Optimized filling: Co-F BC output, Me-F B output, Fi-F C output(2 control line) (A Co-F signal, B Me-F signal, C Fi-F signal)
3. Pause Time (Co-F → Me-F)	After Co-F, start this time, when time up, Me-F I/O Function start output. Initial value:0, range: 0~99.9 (Unit :s)
4. Pause Time (Me-F →)	After Me-F, start this time, when time up, Fi-F I/O Function start output. Initial value:0, range: 0~99.9 (Unit :s)

Fi-F)	
5. Zero /Tare Prepare For Fill	<p>This parameter is used to control whether zeroing or tare before batching. Initial value: Close ; Option:Close, ZERO:Excute zeroing function before batching, TARE: Excute tare function before batching.</p>
6. Tare Range Control ON/OFF	<p>Tare Range Control ON/OFF. Initial value: OFF; ON/OFF option. (Note: when turn on 7~8 parameters can find)</p>
7. Tare Up Limit	<p>When Zero /Tare Prepare For Fill is tare and Tare Range Control is ON, controller is on running condition, to test current weight is in the range, if in the range, start process range, if not, back to stop state.Under the stop state, to input the tare, the current weight also needs to be judged in the range .Within the range ,tare is valid.Initial value:0; range: 0~full scale</p>
8. Tare Low Limit	<p>When Zero /Tare Prepare For Fill is tare and Tare Range Control is ON, controller is on running condition, to test current weight is in the range, if in the range, start process range, if not, back to stop state. Under the stop state, to input the tare, the current weight also needs to be judged in the range .Within the range ,tare is valid. Initial value:0; range: 0~full scale</p>
9. Gross Sign Correction	<p>Initial value: OFF; ON/OFF option. When turn on, controller show weight is negative, automatically reverts to 0 under the stopped state,the stable state and gross sign within zero range.</p>
10. DISC Control	<p>Initial value: DICS Batching Finish; option: DICS Batching Finish / DICS Filling Finish DICS Batching Finish: after all supplement batching finish, starts DICS DICS Filling Finish: after batching one supplement, starts DICS</p>
11. DISC Permission	<p>Initial value: OFF; option: ON/OFF ON: after batching, need DISC Permission signal starts DICS; OFF: after batching, no need DISC Permission signal allow DICS</p>
12. DISC Delay Timer	<p>In the discharge process , current weight lower than Near Zero Band starts DISC Delay Timer, after DISC Delay Timer stop DICS (DICS output invalid) Initial value:0.5, range: 0~99.9 (Unit :s)</p>
13. DISC Monitor Time	<p>After DISC signal valid starts timing, when DISC Monitor Time is up, but DISC signal is still valid, output alarm. Initial value:0.5, range: 0~99.9 (Unit :s) Note:Turn off the DISC monitor function when set to 0.</p>
14. Batching Monitor Time	<p>When system cannot complete the corresponding batching process within the set time, the alarm will be output Initial value: 0; range: 0.0~999。 (Unit:s) Note:Turn off the batching monitor function when set to 0.</p>

15.STAB Prepare For Changing	Initial value: OFF; option: ON/OFF ON: After one kinds of material finish batching ,before batching next material need to judge stable. OFF:After finish batching, the next material start to batching directly.
[More]–[Page 1] parameter, set OVER/UNDER, Auto Free Fall Correction, JogFlow ON/OFF etc parameter.	
1. OVER/UND ER Check	"ON/OFF"option,when this parameter set"ON" , value process starts OVER/UNDER Check
2. Over/Under pause ON/OFF	"ON/OFF"option,when this parameter set"ON" , value process appear Over/Under, controller pause wait for user’s processing. I/O function input E-Stop, back to stop state, clear alarm;
3. Over/Under Alarm timer	No manual Clear History Data Info., alarm timer is up, Over/Under alarm closed automatically Initial value:0.5, range: 0~99.9 (Unit :s)
4. Compensation Times	When the quantitative process is judged to be under, fine filling will be carried out according to this value. When the number of filling time is up, if it is still under, then directly stop compensation and output the over and under alarm. When set to 0, the filling function is off. Initial value:3; range: 0~99
5. Fill-ON Timer	Filling outputting, one circle, fine filling valid time. Initial value:0.5, range: 0~99.9 (Unit :s)
6. Fill-OFF Timer	Filling outputting, one circle, fine filling invalid time. Initial value:0.5, range: 0~99.9 (Unit :s)
7. Free fall correction Reference Samples PCS	The free fall value is the weight value that does not fall into the controller bucket after closing the fine filling signal. Carry out free fall correction according to the actual free fall value according to the requirements of correction. When set to 0, turn off free fall correction. The controller will be set the number of the average value of the average value of the fall, as the basis for the correction of the fall. Initial value:0; range: 0~99
8. Free fall Correction Effective Range	When the free fall value exceeds the set range, the free fall value will not be included in the arithmetic average range. Initial value : 0.2 ; range: 0.0~9.9 (target value %)
9. Free fall	Every Free fall Correction Percentage

Correction Percentage	Initial value : 50% 。 Option: 100%、50%、25% 。
10. JogFlow ON/OFF	“ON/OFF” option, set to “ON” Controller starts fine filling. Initial value : OFF
11. JogFlow ON Timer	Fine filling JogFlow output, an on-off cycle, fine filling effective time. Initial value:0.5, range: 0~9.9 (Unit :s)
12. JogFlow OFF Timer	Fine filling JogFlow output, an on-off cycle, fine filling ineffective time. Initial value:0.5, range: 0~9.9 (Unit :s)
[More]-[Page 3] Peripheral stirring function parameters	
1. Peripheral stirring mixer	Initial value: OFF; Option: ON/OFF ON: Use peripheral stirring function; OFF: Use original string function (hopper mixer)
2. Peripheral Blending time	After finishing the last kinds of material DISC, after the blending time arrives, stir mix signal output is invalid. Initial value:0.5, range: 0~99.9 (Unit :s)
3.Release Time	Time of discharge from mixer to container . After mixing,start this time and output the mixer discharge signal.The mixer discharge signal is invalid after the delay time . Initial value:0.5, range: 0~99.9 (Unit :s)
4.Delay after Release	The mixer enters the waiting state after discharging.After the delay,the mixer enters the idle state.Only the mixer is in the idle state,the controller can discharge. So before discharging after each batching ,it's necessary to judge whether the mixer is in the idle state.Initial value:0.5, range: 0~99.9 (Unit :s)

4.2 Calibration

Calibration should be done when a GM9907-LB controller is used at the first time, or the preset parameters can't meet the user's demand due to change any part of the weighing/bagging system.

To enter calibration parameter need to input correct password as it is protected by password per International Standard. Calibration password can be modified by clicking any parameter requiring permission. (Initial password: **0000**)

Calibration interface, provide two kinds of calibration methods: weight calibration and supplement calibration.The calibration steps are as follows:

Calibration parameter	Item parameter	Description
-----------------------	----------------	-------------

	1.Unit	Initial value: kg . Option: g/kg/t/lb .
	2. Decimal point	Initial value: 0.00 . Option: 0~0.0000.
	3 Minimum division	Initial value: 1 ; 1/2/5/10/20/50/100/200/500
	4 Full capacity	Initial value: 100.00 ; Full capacity \leq minimum division \times 100000
	5. Weight Correct Coefficient/WT Correct	After calibration, if the zero is correct, the weight deviation exists, which can be used to correct the weight value. How this value is calculated: if the controller shows the weight as A, but the weight after weighing is B, the correction factor is calculated as :(actual weight B \times current correction factor)/ indicated weight A Initial value: 1.00000 ; range: 0.00001~9.99999
Zero Calibration	<p>Zero Calibration is to calibrate the zero position of the scale platform. There are two ways for zero calibration: automatic acquisition and manual input. When the new equipment or weighing structure is adjusted, the "automatic acquisition" method must be used for zero calibration.</p> <p>Automatic acquisition: Calibration success conditions: the metering bucket emptied, balance platform stable. After empty the scale, controller displays the current millivolt. Press [Calibration Zero] to calibrate the current state as zero state.</p> <p>Manual input: Manually input zero corresponding to millivolt value, click [Cal ZERO By Valtage], input the recorded zero voltage value in the pop frame to calibrate as zero. The voltage value is the data recorded when the weight is calibrated. The recorded value is used for manual input.</p>	
Calibration Weight	<p>The function of weight calibration is to use the weight calibration method in the field. Here are the steps:</p> <p>Step 1: According to the demand to choose units, decimal point, Minimum division and other weighing parameters</p> <p>Step 2: To Calibration Zero, refer to the calibration steps of the Calibration Zero.</p> <p>Step 3: Put the weights on the weighing table, and when the weighing table is stable, click [Calibration Weight], input the weight of the weights in the bullet frame, and click "Enter" to complete the calibration of the weights.</p>	

Theoretical Calibration	<p>Theoretical value calibration is to carry out weight calibration by inputting the sensitivity and range of the connected load cell</p> <p>Steps as follow:</p> <p style="padding-left: 40px;">Step 1: According to the demand to choose units, decimal point, Minimum division and other weighing parameters</p> <p style="padding-left: 40px;">Step 2: Click [<i>Theoretical Calibration</i>] and set the total range of the load cell in the pop-up frame (if connect multiple load cells and input the total range of the load cell).</p> <p style="padding-left: 40px;">Step 3: Set load cell sensitivity (if connect multiple load cells and enter average sensitivity)</p> <p style="padding-left: 40px;">Step 4: Turn on the " Theoretical Calibration " ON/OFF, then the interface will display " Theoretical Calibration In Use "</p>
-------------------------	---

4.3 Weighing Parameter

In the menu interface, click the [*Weighing*] menu to enter the current parameter item to view and set the home parameter information

Parameter	Item parameter	Description
Weighing parameters	1. PWR-ON Zero Range	When power on start PWR-ON Zero (The weight of the scale bucket meets the PWR-ON Zero Range) Initial value: 0%; parameter range: full range 0%-99%
	2. STAB Range	In the time of stability, the weight change range within this setting value is judged to be stable by the controller Initial value: 3; range: 1~99(d)
	3. STAB Time	Initial value: 0.3; range: 0.1~9.9
	4. D-Filter Strength	D-Filter Strength level 0: no filter; 9: filter effect is strongest Initial value: 7 range: 0~9
	5. Vib-Filter	ON/OFF option, On the basis of D-Filter, secondary filtering is carried out. Initial value:OFF
	6. Zero Range	Zero Range Initial value: 50; range: 1~99 (full range %)
	7. TrZero Range	Weight value within this range , controller zeroing automatically. When the value is 0, do not zero tracking Initial value:0, range: 0~9(d)
	8. TrZero Time	Initial value: 2.0; range: 0.1~99.9 (Unit :s)
	9.A/D Sample Rate	A/D Sample Rate 120tims/s, 240tims/s, 480tims/s, 960tims/s option. Initial value: 480tims/s

4.4 I/O Module

GM9907-LB has equipped with 12 input ports and 16 output ports if with expansion board to connect with other devices. Input, output factory default definition as follow (Output ports **1-16** matches with **OUT1~OUT16**, Input ports **1-12** matches with **IN1~12**)

Default definition:

Output		Input	
OUT1	O6 1st Supplement	IN1	I8 M-Disc/DISC Permission
OUT2	O7 2nd Supplement	IN2	I1 Start
OUT3	O8 3rd Supplement	IN3	I2 Pause
OUT4	O9 4th Supplement	IN4	I3 E-stop
OUT5	O10 5th Supplement	IN5	I6 Clear Alarm
OUT6	O11 6th Supplement	IN6	I7 Change Recipe
OUT7	O3 CO-F	IN7	I9 TARE
OUT8	O4 MI-F	IN8	I10 Clear Tare
OUT9	O5 FI-F	IN9	I11 Start/Stop
OUT10	O18 Value	IN10	I2 Manual Stir
OUT11	O19 OVER/UNDER	IN11	I0 None
OUT12	O22 DICS	IN12	I0 None
OUT13	O23 NearZero		
OUT14	O25 Alarm		
OUT15	O30 Stir		
OUT16	O1 run		

4.4.1 Output port & input port definition

The output port and the input port can be defined according to the application content. In I/O interface:

I/O module description

Output		
Code	Content	Explanation
O0	Undefined	Undefined if output port is O0.
O1	Running	The output signal is defined valid in run state.
O2	Stopped	The output signal is defined valid in stop state.
O3	Co-Fill	Coarse discharge port for controlling filling mechanism.In

		the process of filling, when the current weight is less than the target value - Co-Fill Remain, the output signal is defined as valid.
O04	Me-Fill	The middle discharge port is used to control the filling mechanism. In the process of filling, when the current weight is less than the target value - Me-Fill Remain, the output signal is defined as valid
O05	Fi-Fill	A fine discharge port for controlling the filling mechanism. In the process of filling, when the current weight is less than the target value- Over Limit Value, the output signal is defined as valid.
O06	1st Supplement	Controller is in charge of No. 1 batching, this signal is valid.
O07	2nd Supplement	Controller is in charge of No. 2 batching, this signal is valid.
O08	3rd Supplement	Controller is in charge of No. 3 batching, this signal is valid.
O09	4th Supplement	Controller is in charge of No. 4 batching, this signal is valid.
O10	5th Supplement	Controller is in charge of No. 5 batching, this signal is valid.
O11	6th Supplement	Controller is in charge of No. 6 batching, this signal is valid.
O12	7th Supplement	Controller is in charge of No. 7 batching, this signal is valid.
O13	8th Supplement	Controller is in charge of No. 8 batching, this signal is valid.
O14	9th Supplement	Controller is in charge of No. 9 batching, this signal is valid.
O15	10th Supplement	Controller is in charge of No. 10 batching, this signal is valid.
O16	11th Supplement	Controller is in charge of No. 11 batching, this signal is valid.
O17	12th Supplement	Controller is in charge of No. 12 batching, this signal is valid.
O18	Result Waiting	Used to indicate the end of the filling process. This signal is

		valid from the end of Fi-Fill to the time before DICS.
O19	Over/Under	When Over/Under, this signal is valid.
O20	Over	When is Over, this signal is valid.
O21	Under	When is under, this signal is valid.
O22	DISC	Used to control bucket's discharge door. The signal is effective after the result waiting timer, so that the supplement is discharged from the measuring bucket into the packaging bag.
O23	NearZero	This signal is valid if the current net weight is less than the set value of the NearZero zone.
O24	STAB	When STAB is valid, current output is valid.
O25	Alarm	When Controller appears OVER/UNDER, batch No.is up, alarm, this output is valid.
O26	Batch Complete	This output is valid when the controller has completed the set batch.
O27	Pause	When the controller is in pause state, this signal is valid.
O28	Batch Done	This signal is effective when the 12 supplements (all supplements) are matched and the result waiting timer is up.
O29	DISC Done	The signal is valid when the controller discharge is completed, and the effective time is 1s.
O30	Stir	When controller is in Stir state, this signal is valid.
O31	OFL	When controller is OFL, this signal is valid.
O32	ZERO Failed	When the scale is not stable or the weight is not within the range of zeroing, the instrument is effective for zeroing operation.
O33	Blender Release	Start the external mixer mode, output I/O function defines the mixer discharging signal at this time the discharging output is valid
Input		
I0	Undefined	Undefined if input port is 0
I1	Start	This signal is valid in running state. (Pulse input signal)
I2	Stop	Finish current package and then return to stop state. (Pulse input signal)
I3	E-Stop	Emergency stop, Return to stop state if signal is valid.

		(Pulse input signal)
I4	Pause	When in running state, this signal is valid, controller will enter pause state, and this input is pulse input signal.
I5	ZERO	The signal effective controller will realize gross zero clearance.This input is a pulse input signal.
I6	Clear Alarm	Used to clear the alarm output of the controller.This input is a pulse input signal.
I7	Change Recipe	This input is valid once, increments the recipe number by 1, and returns 1 when the recipe number is greater than 20.If a recipe has a target value of 0, the recipe is skipped.
I8	M-Disc/DISC Permission	Used to manually remove the supplement in the metering bucket under the stop state.The input is valid for the first discharge output, and invalid for the second effective discharge output. Under the running state, it is input as the discharge allowed signal.
I9	TARE	If the signal is valid under the condition of tare, the current weight will be taken as the tare weight to perform the tare operation
I10	Clear Tare	If the signal is valid and meets the condition of Clear Tare, the Clear Tare operation is performed and the gross weight is returned.
I11	Start/Stop	The signal effective controller will enter the running state, this input is the level input signal.
I12	Manual Stir	When this signal is valid, controller will enter stir state.
I13	Allow release	Turn on the external mixer mode to take effect. If this signal is defined, wait for the allowable signal of discharge. If no signal is defined, discharge directly.
I14	Print All Supplement ACUM Data	In the stop state, this signal is valid. The controller prints the cumulative of all materials in the current recipe.
I15	Print All Recipe ACUM Data	In the stop state, this signal is valid. The controller prints all the recipes accumulated.

4.5 Maintenance

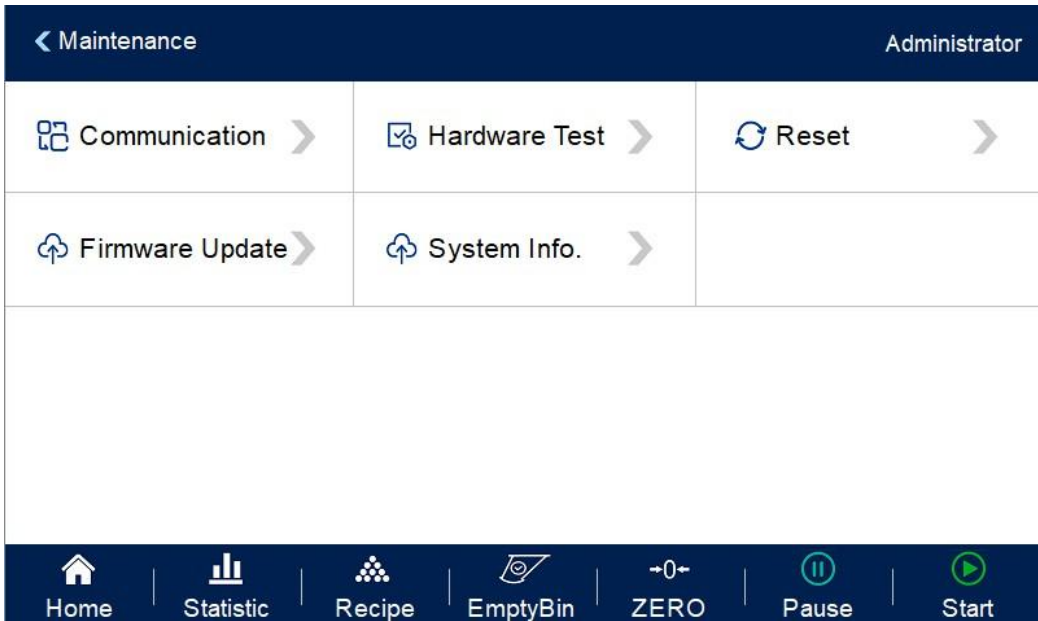

4.5.1 Communication Setting

GM9907 provides two serial communication interface; See Section 2.5 for the definition of serial port output; correct setting of port parameters can be used for communication.

Communica tion parameters	Item Parameters	Description
Serial port parameters (Serial port 1. RS232 Serial port 2. RS485)	ID No.	Initial value: 1. Option: 1~99.
	Baud rate	Initial value: 38400 ; 9600/19200/38400/57600/115200
	Communication mode	Initial value: Modbus-RTU.Modbus-RTU, rE-Cont, rE-Read, tt, rS-Cont, rS-Read, Print.
	Data format	Initial value: 8-E-1 (8 data bits - even parity -1 stop bit). 8-E-1、8-N-1、7-E-1、7-N-1
	Modbus Hi-Lo	Modbus communication mode: Initial value: AB-CD (Hi ahead); AB-CD (Hi ahead)、 CD-AB (Low word first) (The mode of communication is visible with MODBUS-RTU parameters)
	Send Interval	The time interval between frames in continuous transmission.Range 0-1000ms, default value: 50ms. (The mode of communication is visible with tt ,

		<i>rE-Cont</i> 、 <i>rS-Cont</i> parameters)	
	Send Checksum	Whether to send a checksum under the TT (Toledo Continuous Mode) protocol. On/off optional, off by default.	
Ethernet parameters	Communication Mode	Modbus-TCP, address please refer to section 6.5.3	
	Hi-Lo	Modbus communication display method: Initial value: AB-CD(Hi ahead); AB-CD(Hi ahead /CD-AB(Low word first))	
	port number	Initial value: 502 ; 1~65535	
	IP		Initial value: 192 Range: 0~255
			Initial value: 168 Range: 0~255
			Initial value: 101 Range: 0~255
			Initial value: 246 Range: 0~255
	Subnet mask	255.255.255.0	
Gateway	192.168.101.254.		
MAC	BC.66.41.9X.XX.XX.		
Print	Auto Print	On/Off is optional; when “On” is selected, the package result will be printed out automatically every time the package is completed (the serial port should be selected as “Print”). Initial value: off.	
	Printer Format	Initial value: 24 columns of printing ; 24 columns of printing / 32 columns of printing.	
	Print Language	Initial value: Chinese ; Chinese / English optional.	
	Print Empty Line Nos.	The number of lines after the print is completed. Initial value: 3 ; 0~9 optional.	

4.5.2 Hardware Test

This can check whether the output and input interfaces of the instrument are normally connected with external devices through IO test. Before I/O test, I/O test switch on, and then I/O test.

Output port test: under the IO test interface, start the output test, that is, after clicking the corresponding output port button, the color of the interface port will light up. The output state of the corresponding external connection should be valid. If it is invalid, it indicates abnormal connection.

Input port test: in the IO test interface, when the external input signal is valid, the corresponding input port color under the interface will be lit up to green. When the external

input is valid, the interface has no response, indicating abnormal connection. Check the power input and wiring of the I/O Module, etc.

4.5.3 Factory Reset

Administrators and system administrators can restore and backup data through the restore factory in *[Maintenance]*.

Factory Reset	1. All(Except Calibration)	Click this item to restore all parameters of the meter (except calibration parameters) to factory setting values.
	2. All	Click this item to restore all parameters of the instrument to factory setting values.
	3. Recipe	Click this item to restore formula parameter value as factory setting value.
	4. Calibration	Click this item to restore the calibration parameter value to factory setting value.
	5. Communication	Click this item to restore communication setting parameter value is factory setting value.
	6. Weight Format	Click this item to restore the property parameters of weighing to the factory setting value.
	7. I/O Function	Click this item to restore switch value definition parameter value as factory setting value.
	8. ACUM	Click this item to restore supplement ACUM and recipe ACUM as factory setting value.

4.5.4 Software upgrade

You need to be a system administrator to make software upgrades. Refer to Section 5.11 to upgrade USB flash disk for details.

4.5.5 System info.

System info.	Permission Auto Logout	Permission exit time setting. can choose 5 minutes, 10 minutes, 20 minutes,30 minutes.
	Recipe Target Display	On/Off is optional; when “On” is selected,the target value of each material tank can be displayed on the main interface.
	Calibration Times	Display the calibration times.
	Calibration Checksum	Display the calibration checksum.
	Backlight Switch	The screen goes out when the backlight is turned on.
	Backlight Length Of	Turn on the backlight and set the backlight time.

	Time	When the time is over ,the screen goes out .Click the screen to re-light up. Initial value: 15s; Range: 15~1800.(s)
--	------	--

4.6 Statistics

In the main interface, click **[Statistics]** to enter the interface. Users can view the supplement accumulation, formula accumulation and historical record under the parameter "Statistics", and carry out operations such as U disk export or data clearance on the historical record.

- ◆ In **[Supplement ACUM]**, check the current receipt ACUM and each supplement ACUM weight. Click **[Data Edit]** to print the supplement ACUM of the current recipe and clear recipe ACUM data.
- ◆ In **[Recipe ACUM]**, Check the cumulative weight and cumulative times of each formula No., Click the right side of the interface to switch the Supplement 1-7,8-14 and 15-20. Click **[Data Edit]** to clear all recipe ACUM data and print all recipe ACUM data.
- ◆ In **[History Data]** interface, can check history data. Click **[Data Edit]**, the History Data can be exported through the U disk, also can clear the History Data. (Note: #1 refers to the materials filling sequence, not the tank No.)

5. Function Description

5.1 Batch

Batch number is the number of automatic batching controller, set the range of 0 ~ 9999, in the process of automatic complete set by the number of times, controller issued a number of times to alarm and shutdown, wait for the user processing, batch number and alarm output, at this time to remove alarm button or "alarm" input signal effectively, controller will clear the alarm, at the same time return to stop state.

If the batch number is set to 0, if the "Continuous Batching ON/OFF " is off, the batch number judgment will not be carried out. After the discharge is completed, it directly enters the stop state; If opened, enter the next ingredient.

If in the mode of each supplement, only after the completion of the last supplement discharge, to judge whether the number of batches is completed

5.2 Batching Process Order function

The "Config Numbers of Supplement" for recipe parameters determines the setting range for the number of recipe parameters.

Example: if " Config Numbers of Supplement " is set to 5, 5 kinds of supplements can be batched, and the process sequence of formula parameters can only set the ingredients parameters of 5 cans. If the number of cans set exceeds " Config Numbers of Supplement ", an error will be warned when returning to the interface.

In the process sequence, the supplement is batched in sequence, in which the supplement tank number and supplement batching parameters can be set

The tank number can be set repeatedly. The tank number refers to the serial number of external supplements, not the serial number of supplement filling sequence

5.3 ACUM content check and clear

[Statistic] interface can check ACUM content and clear ACUM.

The *[Supplement ACUM]* interface reads the ACUM and total ACUM situation of the 12 supplements with the current formula number

The *[Recipe ACUM]* interface can switch Recipe number to read the ACUM and click any formula to clear the selected recipe ACUM.

The *[History Data]* interface records the filling time of each scale, recipe number, the

target value of each supplement filling sequence and the actual ingredients value.(#1 refers to the filling order of supplements, not the tank number)

[Data Edit] only clears the historical data in the "History Data" interface, and does not clear the accumulation.Clear cumulative steps: "maintenance" -> "restore factory" -> "reset ACUM parameters".

5.4 Manual DICS/DICS allow

In the stop state, the external input "manual DICS" signal, the controller discharge output is effective;Input "manual discharge" signal again, the controller discharge output is invalid.

In the running state, after the completion of Result Waiting, the discharge operation shall be carried out when the "DICS allow" signal is effective and the " DICS output" of the controller is effective.

5.5 Manual Zeroing

In the stop state, the external input "zero" signal, can reset the controller gross weight.(The current reset operation should be in a stable state and the gross weight within the reset range, otherwise the controller will not reset, and display "when reset, the scale body is not stable" or "when reset, the current weight beyond the reset range" error message).

5.6 Power Loss Resume

(1) When "Power Loss Resume ON/OFF" is on, the controller has Power Loss Resume function.When the controller suddenly power off, to be power on again, can restore the working state before power off.

(2) No matter "Power Loss Resume ON/OFF" is on or off, the controller suddenly power off in the stop state(The batching has been completed). After power on again, enter the current weighing display state.

(3) When "Power Loss Resume ON/OFF" is on, controller has the power-down save function.When the controller is in the working state, the power suddenly falls off. When the power is re-energized, it asks "Restore power?", select "OK" to restore the working state before the power loss, and complete the batching process before the power loss;Select

"Cancel" to enter the current weighing display state.

5.7 Compensation Function

When "Over/Under alarm ON/OFF" is turned on and the current batching result is judged to be Under, controller will automatically start the Compensation function (the "Compensation Times" is set to non-0) for filling operation. When the current batch result is still Under after the set number of filling, the "Under" alarm signal will be output and the batching process will continue after the OVER/UNDER alarm timer arrival.

In the process of compensation, controller will decide which filling method to use by itself according to the comparison of the results of ingredients and the weight value of each stage.

5.8 Free Fall Correction

When the "free fall correction sampling times" is not 0, the controller will automatically correct the drop value according to the results of the ingredients during the batching process.

“Free fall correction sampling times”: the controller averages the set number of times of drop values, which is used as the basis for drop correction.

“Free fall correction range”: when the current drop value exceeds the set range, the current drop value will not be included in the arithmetic average range.

5.9 DICS monitoring function

After “DICS signal” is valid, start “DICS monitoring function”, if “DICS monitoring function” is finished, DICS signal is still valid, output alarm signal, after back to stop state automatically. When DICS monitoring function is set to "0", turn off DICS monitoring function.

5.10 Batch monitoring function

In batching process, in “batch monitoring time” setted time can’t finish batching process, output “batch overtime”, back to stop state automatically. When batch monitoring timer is set to “0”, turn off filling monitor function.

5.11 USB disk update software

5.11.1 Foreground update process

Steps as follow

1.	Plug the USB drive containing the upgrade kit “tpcbakup” into the controller.
2.	Power up the controller, and the message "You are using the comprehensive function package of megsTpc U disk, click 'Yes' to enter the system setting interface and start the comprehensive function package, click' No 'to exit";Click "Yes" and the "User Project Update" button pops up
3.	After clicking the "User Project Update" button, select the project to download
4.	After download will restart automatically

5.11.2 Background update process

Steps as follow

1.	Insert U disk to computer, creat new folder "GM9907 - LB" in the U disk;
2.	Save “ GM9907-L-Upload.gm ” to folder “ GM9907-LB ”
3.	Plug the USB disk into the controller, switch to the system administrator authority, to the System Maintenance - Software Upgrade interface, long press the blank in the lower right corner of 5S, and the " Update " button pops up, jump to the upgrade interface, click " Update ", click " Update " again, and the words " Updating " appear, controller is upgrading the background
4.	When the progress bar is finished, the upgrade will be successful after the countdown of 10s and the login interface will be switched to

5.12U disk update boot interface

Steps as follow:

1.	Save the image file (resolution 800*480, format.bmp) into the root directory of U disk containing the project package (tpcbakup)(Note: the upgrade kit "tpcbakup" is different from this tpcbakup)
2.	Insert U disk to controller
3.	Controller pops up the display of 【USB disk k it】 , and select “Update startup bitmap”.
4.	Enter the LOGO selection interface, select the picture to be upgraded, and click OK. It will prompt you to restart after successful bitmap update

5.13 Peripheral stirring function

The hopper stirring function is shielded when the external stirring function is turned on. After discharge (last bucket) is completed, enter the peripheral stirring process:

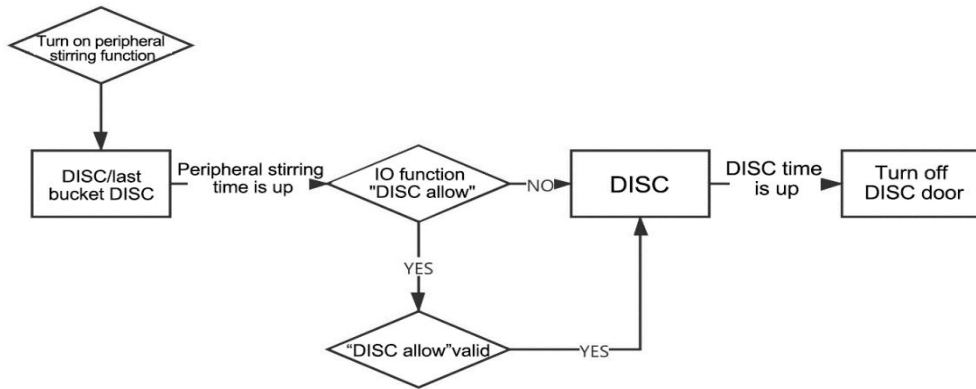

Note: Mixer discharge allow two applications.

(1) When mixer is idle, as the external mixer manual discharge input, press the external mixer discharge at this time, release the external mixer to stop discharging, discharge time is determined by press time.

(2) In the process of waiting for discharging permission in the busy state of mixer, input as discharge permission of mixer, press and stop discharge after a set discharge time

5.14 Stiring Function(Original Stiring Function)

If the peripheral blender switch is off,the stiring function is valid.Include two kinds of stir control mode ,Stir after fill and stir when fill.

Stir when fill

In the process of filling, When start to fill, after the stir predelay time reaches, output the mixing signal ,at the same time ,the fine flow finished. After the delay after stir time reaches, stop output the mixing signal.

Stir after fill

After finishing the result waiting, start to fill, after the stir predelay time reaches, output the mixing signal .The effective time of this signal output is the sir time. Then after the delay after stir time reaches, stop output the mixing signal.

6. Communication Description

GM9907 can support two serial ports , serial 1 and serial 2 both can choose modbus-RTU, rE-Cont(rE continue mode), rE-Read(rE command mode),tt(Toledo protocol),rS-Cont(rS continue mode),rS-Read(rS command mode),Print. Controller the first serial port is RS-232, the second serial port is RS-485.

6.1 RE protocol

This protocol has two working mode : continue mode (**Cont**) /command mode (**Read**) .Code is **ASCII**.

6.1.1 rE-Cont

Continuous mode in the RE communication format. In the communication setting, the communication mode selected by serial port 1 or serial port 2 is RE-CONT protocol.In this way, there is no need to send any command to the controller, and the controller will automatically send the collected data to the host computer.The data frame format is as follows:

state	,	GW/NW	,	signal	Display value	Unit	CR	LF
-------	---	-------	---	--------	---------------	------	----	----

Among them:

- State —— 2unit, overflow OL: (**4FH 4CH**); stable ST: (**53H 54H**); unstable US: (**55H 53H**)
- , —— 1unit, separator **2CH**
- GS/NT—— 2unit, 2unit, Gross weight GS (**47H 53H**), Net Weight NT (**4EH 54H**)
- Signal —— 1unit, **2BH** (+) **2DH** (-)
- Display—— 7unit, contain decimal point, when no decimal point hi way is 0
- Unit —— 2unit, **Kg** (**4BH 67H**)
- CR —— 1unit, **0DH**
- LF —— 1unit, **0AH**

For example, when the controller automatically sends the following frame of data

53 54 2C 47 53 2C 2B 30 31 31 2E 31 32 30 4B 67 0D 0A

Can know current controller state: stable, data is positive, current weight value is 11.120kg

6.1.2 rE-Read

The command mode under the RE communication format. In the communication setting, the communication mode selected by serial port 1 or serial port 2 is RE-READ protocol. In this way, controller will only send the current data to the host when it receives the command. The format of command data frame sent by the host computer to the controller is as follows:

R	E	A	D	CR	LF
52H	45H	41H	44H	0DH	0AH

The format of controller response data frame is consistent with that of continuous mode data frame.

Response data format

State	,	GS/NT	+ - value	Display value	unit	CR	LF
-------	---	-------	-----------	---------------	------	----	----

Among them:

- State —— 2unit, overflow OL: (**4FH 4CH**); stable ST: (**53H 54H**); Unstable US: (**55H 53H**)
- , —— 1unit, separator **2CH**
- GS/NT —— 2unit, 2unit, Gross weight GS (**47H 53H**), Net weight NT (**4EH 54H**)
- Signal —— 1unit, **2BH** (+) **2DH** (-)
- Display value —— 7unit, contain decimal point, when no decimal point hi way is 0
- Unit —— 2unit, **Kg** (**4BH 67H**)
- CR —— 1unit, **0DH**
- LF —— 1unit, **0AH**

For example:

Command: **52 45 41 44 0D 0A**

Respond: **53 54 2C 47 53 2C 2B 30 31 31 2E 31 32 30 4B 67 0D 0A**

Can know current controller state: stable, data value is +, current value is **11.120kg**.

6.2 RS protocol

This protocol has two working mode : continue mode (**Cont**) /command mode (**Read**) .Code is ASCII.

Note: In RS mode, all the password items are unreadable, and all the calibration items can only be modified in the stop state

6.2.1 rS-Cont

The continuous mode under the RS communication format. In the communication setting, the communication mode selected by serial port 1 or serial port 2 is RS-CONT protocol. In this way, there is no need to send any command to the controller and the controller will automatically send the collected data to the host computer. The data frame format is as follows:

STX	Scale No.	R	S	Supplement No.	state1	state2	G/N	+/-	Display value	CRC	CR	LF
-----	-----------	---	---	----------------	--------	--------	-----	-----	---------------	-----	----	----

Among them:

- STX — 1unit, start signal **02H**
- Scale No. — 2unit, 2unit, range **01-99**, if **01** is **30H 31H**
- R — 1unit, **52H**
- S — 1unit, **53H**
- Supplement No. — 2unit, **00~04 (30H 30H~30H 34H)** **00** means stop state
- State 1:

D7	D6	D5	D4	D3	D2	D1	D0
Fix 0	Fix 1	1—Fi-fi ll/ 0—No	1—Me- fill/ 0—No	1—Co- fill/ 0—No	1—before fill/ 0—No	1—paus e/ 0—No	1—Run/ 0—Stop

e 2:

D7	D6	D5	D4	D3	D2	D1	D0
Fix 0	Fix 1	1—OF L/ 0—No	1—Stab le/ 0—No	1—batch finish/ 0—No	1—DIS C/ 0—No	1—WAI T/ 0—No	1—FINISH/ 0—No

- G/N — 1 unit, 0-GS 1-NT
- +/- — 1unit, signal: **2BH (+)**、**2DH (-)**
- Display value — 7unit, contain decimal point
- CRC — 2unit, Checksum, in which all preceding values are added and converted to decimal, and then the last two digits are taken and converted to ASCII code

- CR —— 1unit, 0DH
- LF —— 1unit, 0AH

For example

When the controller automatically sends the following frame data:

02 30 31 52 53 30 31 79 50 41 2B 30 30 30 32 2E 30 30 30 36 0D 0A

Can know #1 controller is in 1#, Co-fill, stable, NT, display value+2.00 state.

6.2.2 rS-Read

The continuous mode under the RS communication format. In the communication setting, the communication mode selected by serial port 1 or serial port 2 is RS-Read protocol. In this way, controller will only send the current data to the host when it receives the command. Read different controller parameters, send different commands, get a different response format. The details are as follows:

- Host computer read out "current state"

Command:

STX	Scale No.	R	S	CRC	CR	LF
-----	-----------	---	---	-----	----	----

Controller receives the correct response: [Same as RS communication format continue method.](#)

Controller receive error respond

STX	Scale No.	R	S	N	O	CRC	CR	LF
-----	-----------	---	---	---	---	-----	----	----

For example:

Read current state command 02 30 31 52 53 36 34 0D 0A

Controller receive correct respond: 02 30 31 52 53 30 31 79 50 41 2B 30 30 30 32 2E 30 30 30 36 0D 0A

Current controller state: 1#, Co-fill, state, NT, display value+2.00

- Through host computer process" calibrate Decimal Point"

Write command:

STX	Scale No.	C	P	Decimal Point Places	CRC	CR	LF
-----	-----------	---	---	----------------------	-----	----	----

Controller receive correct respond

STX	Scale No.	C	P	O	K	CRC	CR	LF
-----	-----------	---	---	---	---	-----	----	----

Controller receive error respond

STX	Scale No.	C	P	N	O	CRC	CR	LF
-----	-----------	---	---	---	---	-----	----	----

Among them:

- C — 1unit, 43H
- P — 1unit, 50H
- Decimal Point Places — 1unit, range 0~4
- For example: Calibrate #1 scale Decimal Point as 3
02 30 31 43 50 33 39 37 0D 0A
- Controller receive correct respond:
02 30 31 43 50 4F 4B 30 30 0D 0A
means: The data written to scale 1 has been saved correctly

- Through host computer read “Calibrate with weight zero”

Write command:

STX	Scale No.	C	Z	CRC	CR	LF
-----	-----------	---	---	-----	----	----

Controller receives correct response:

STX	Scale No.	C	Z	O	K	CRC	CR	LF
-----	-----------	---	---	---	---	-----	----	----

Controller receives incorrect response

STX	Scale No.	C	Z	N	O	CRC	CR	LF
-----	-----------	---	---	---	---	-----	----	----

Among them:

- Z — 1unit, 5AH
- For example: Add weight to No. 1 scale to mark zero
02 30 31 43 5A 35 36 0D 0A
- Controller receives correct response:
02 30 31 43 5A 4F 4B 31 30 0D 0A
Means the command was executed correctly

- Through host computer read “Calibrate without weight zero”

Write command:

STX	Scale No.	C	Y	DDDDDD	CRC	CR	LF
-----	-----------	---	---	--------	-----	----	----

Controller receives correct response:

STX	Scale No.	C	Y	O	K	CRC	CR	LF
-----	-----------	---	---	---	---	-----	----	----

Controller receives incorrect response

STX	Scale No.	C	Y	N	O	CRC	CR	LF
-----	-----------	---	---	---	---	-----	----	----

Among them:

- Y — 1unit, 59H
- DDDDDD — 6unit, Six millivolts corresponding to zero
- For example: Send a write zero command to controller to scale # 1
02 30 31 43 59 30 30 31 35 30 30 34 39 0D 0A
- Controller receives correct response:
02 30 31 43 59 4F 4B 30 39 0D 0A
Means data written to scale 1 has been saved correctly

- Through host computer read “Calibrate the minimum index and the maximum range”

Write command:

STX	Scale No.	C	M	DD	DDDDDD	CRC	CR	LF
-----	-----------	---	---	----	--------	-----	----	----

Controller receives correct response:

STX	Scale No.	C	M	O	K	CRC	CR	LF
-----	-----------	---	---	---	---	-----	----	----

Controller receives incorrect response

STX	Scale No.	C	M	N	O	CRC	CR	LF
-----	-----------	---	---	---	---	-----	----	----

Among them:

- M — 1 unit, 4DH
- DDD — 3 unit, 1,2,5,10,20,50,100,200,500
- DDDDDD — 6 unit, full range value
- For example: Send write index value and full range command to scale # 1
02 30 31 43 4D 30 31 30 31 30 30 30 30 32 39 0D 0A
- Controller receives correct response:
02 30 31 43 4D 4F 4B 39 37 0D 0A
Means data written to scale 1 has been saved correctly

- Through host computer read “Weight gain calibrate”

Write command:

STX	Scale No.	C	G	DDDDDD	CRC	CR	LF
-----	-----------	---	---	--------	-----	----	----

Controller receives correct response:

STX	Scale No.	C	G	O	K	CRC	CR	LF
-----	-----------	---	---	---	---	-----	----	----

Controller receives incorrect response

STX	Scale No.	C	G	N	O	CRC	CR	LF
-----	-----------	---	---	---	---	-----	----	----

Among them:

- G — 1 unit, 47H
- DDDDDD — 6 unit, gain value
- For example: Calibrate the gain of 10000 to # 1 scale command

02 30 31 43 47 30 31 30 30 30 30 32 36 0D 0A

- Controller receives correct response:

02 30 31 43 47 4F 4B 39 31 0D 0A

Means 10000 written to scale 1 has been correctly saved

- "Theoretical value calibration" by host computer

Write command:

STX	Scale No.	C	L	DDDDDD	DDDDD	CRC	CR	LF
-----	-----------	---	---	--------	-------	-----	----	----

Controller receives correct response:

STX	Scale No.	C	D	O	K	CRC	CR	LF
-----	-----------	---	---	---	---	-----	----	----

Controller receives incorrect response

STX	Scale No.	C	D	N	O	CRC	CR	LF
-----	-----------	---	---	---	---	-----	----	----

Among them:

- D — 1 unit, 44H
- For example: Send discharge operation to scale 1

02 30 31 43 44 33 34 0D 0A

- Controller receives correct response:

02 30 31 43 44 4F 4B 38 38 0D 0A

Means that the command was executed correctly

- Through host computer process "Manual DICS"

Write command:

STX	Scale No.	C	D	CRC	CR	LF
-----	-----------	---	---	-----	----	----

Controller receives correct response:

STX	Scale No.	C	D	O	K	CRC	CR	LF
-----	-----------	---	---	---	---	-----	----	----

Controller receives incorrect response

STX	Scale No.	C	D	N	O	CRC	CR	LF
-----	-----------	---	---	---	---	-----	----	----

Among them:

- **D** — 1 unit, **44H**
- For example: Send discharge operation to scale 1
02 30 31 43 44 33 34 0D 0A
- Controller receives correct response:
02 30 31 43 44 4F 4B 38 38 0D 0A
Means that the command was executed correctly

➤ Through host computer write "Running"

Write command:

STX	Scale No.	C	R	CRC	CR	LF
-----	-----------	---	---	-----	----	----

Controller receives correct response:

STX	Scale No.	C	R	O	K	CRC	CR	LF
-----	-----------	---	---	---	---	-----	----	----

Controller receives incorrect response

STX	Scale No.	C	R	N	O	CRC	CR	LF
-----	-----------	---	---	---	---	-----	----	----

Among them:

- **R** — 1 unit, **52H**
- For example: Send running operation to scale 1
02 30 31 43 52 34 38 0D 0A
- Controller receives correct response:
02 30 31 43 52 4F 4B 30 32 0D 0A
Means that the command was executed correctly

➤ Through host computer write "STOP"

Write command:

STX	Scale No.	C	J	CRC	CR	LF
-----	-----------	---	---	-----	----	----

Controller receives correct response:

STX	Scale No.	C	J	O	K	CRC	CR	LF
-----	-----------	---	---	---	---	-----	----	----

Controller receives incorrect response

STX	Scale No.	C	J	N	O	CRC	CR	LF
-----	-----------	---	---	---	---	-----	----	----

Among them:

- **J** — 1unit, **4AH**
- For example: Send stop operation to scale 1

02 30 31 43 4A 34 30 0D 0A

- Controller receives correct response:

02 30 31 43 4A 4F 4B 39 34 0D 0A

Means that the command was executed correctly

- Through host computer write "PAUSE"

Write command:

STX	Scale No.	C	S	CRC	CR	LF
-----	-----------	---	---	-----	----	----

Controller receives correct response:

STX	Scale No.	C	S	O	K	CRC	CR	LF
-----	-----------	---	---	---	---	-----	----	----

Controller receives incorrect response

STX	Scale No.	C	S	N	O	CRC	CR	LF
-----	-----------	---	---	---	---	-----	----	----

Among them:

- S — 1 unit, 53H
- For example: Send pause operation to scale 1

02 30 31 43 53 34 39 0D 0A

- Controller receives correct response: :

02 30 31 43 53 4F 4B 30 33 0D 0A

Means that the command was executed correctly

- Through host computer write "TARE"

Write command:

STX	Scale No.	C	Q	CRC	CR	LF
-----	-----------	---	---	-----	----	----

Controller receives correct response:

STX	Scale No.	C	Q	O	K	CRC	CR	LF
-----	-----------	---	---	---	---	-----	----	----

Controller receives incorrect response

STX	Scale No.	C	Q	N	O	CRC	CR	LF
-----	-----------	---	---	---	---	-----	----	----

Among them:

- Q — 1 unit, 51H
- For example: Send tare operation to scale 1

02 30 31 43 51 34 37 0D 0A

- Controller receives correct response:

02 30 31 43 51 4F 4B 30 32 0D 0A

Means that the command was executed correctly

- Through host computer write "Clear Tare"

Write command:

STX	Scale No.	C	O	CRC	CR	LF
-----	-----------	---	---	-----	----	----

Controller receives correct response:

STX	Scale No.	C	O	O	K	CRC	CR	LF
-----	-----------	---	---	---	---	-----	----	----

Controller receives incorrect response

STX	Scale No.	C	O	N	O	CRC	CR	LF
-----	-----------	---	---	---	---	-----	----	----

Among them:

- **O** — 1unit, **4FH**
- For example: Send clear tare operation to scale 1
02 30 31 43 4F 34 35 0D 0A
- Controller receives correct response:
02 30 31 43 4F 4F 4B 39 39 0D 0A

Means that the command was executed correctly

- Through host computer write "ZERO"

Write command:

STX	Scale No.	C	C	CRC	CR	LF
-----	-----------	---	---	-----	----	----

Controller receives correct response:

STX	Scale No.	C	C	O	K	CRC	CR	LF
-----	-----------	---	---	---	---	-----	----	----

Controller receives incorrect response

STX	Scale No.	C	C	N	O	CRC	CR	LF
-----	-----------	---	---	---	---	-----	----	----

Among them:

- **C** — 1 unit, **43H**
- For example: Send zero operation to scale 1
02 30 31 43 43 33 33 0D 0A
- Controller receives correct response:
02 30 31 43 43 4F 4B 38 37 0D 0A

Means that the command was executed correctly

- Through host computer write "Clear Alarm"

Write command:

STX	Scale No.	C	B	CRC	CR	LF
-----	-----------	---	---	-----	----	----

Controller receives correct response:

STX	Scale No.	C	B	O	K	CRC	CR	LF
-----	-----------	---	---	---	---	-----	----	----

Controller receives incorrect response

STX	Scale No.	C	B	N	O	CRC	CR	LF
-----	-----------	---	---	---	---	-----	----	----

Among them:

- **B** — 1 unit, **42H**
- For example: Send clear alarm operation to scale 1
02 30 31 43 42 33 32 0D 0A
- Controller receives correct response:
02 30 31 43 42 4F 4B 38 36 0D 0A

Means that the command was executed correctly

6.3 tt Toledo protocol

In the communication setting, the communication mode selected by serial port 1 or serial port 2 is TT protocol. In this state, the controller will send data continuously in the Toledo protocol

The format of Toledo continuous transmission is as follows:

1	2	3	4	5	6	7	8	9	10	11	12	13	14	15	16	17	18
STX	State A	State B	State C	Display weight (6unit)						Batch accumulate value of this time (6unit)						CR (calibration)	

Among them:

- Starts with standard ASCII starting character 02(STX)
- The state word A is defined as follows

D7	D6	D5	D4	D3	D2	D1	D0
FIX 0	FIX 0	FIX 1	Unit		Decimal point		

Among them:

Unit:

Unit	D4	D3
g	1	0
Kg	0	1
t	0	0
lb	1	1

Decimal point:

Decimal point	D2	D1	D0
0	0	1	0
0.0	0	1	1
0.00	1	0	0
0.000	1	0	1
0.0000	1	1	1

- The state word B is defined as follows :

D7	D6	D5	D4	D3	D2	D1	D0
Reserved	Reserved	Reserved	Reserved	Stable	OFL	Signal	GS/NT
FIX 0	FIX 0	FIX 1	FIX 0	1-Unstable/0-stable	1-OFL/0-normal	1-negative/0-positive	1-NT/0-GS

- The state word C is defined as follows:

D7	D6	D5	D4	D3	D2	D1	D0
Binary represents supplement numbers 1-12							

For example: 0000 0001 Supplement 1; 0000 1100 Supplement 12

6.4 Ethernet communication

GM9907 Configuration of a network communication interface, with RJ-45 crystal head connection, to achieve communication with the host computer or PLC. Using the Modbus-TCP communication protocol, the IP address of the ethernet should be written in the network port parameters of [Maintenance] - [Communication]. After the network cable is inserted, the green indicator light of the network port slot is long and bright, indicating that the network cable is well connected, and the orange indicator light flashes, indicating that network data has been received by the network card. **Modbus-TCP** addresses refer to [6.5.3 of the modbus address](#)

6.5 Printing method

When serial port parameter port 1 or 2 choose print mode, corresponding to the serial port can be connected to a serial printer to print the contents accumulated by implementation-dependent.

Print mode communication parameters refer to serial port parameters, need to note:

- 1) **Baud Rate**——parameters need to consist with connected printer.
- 2) **Communication format**——parameters need to consist with connected printer.

Note: When printing options for Chinese language, can not use the data bits to 7 formats, otherwise there will be printing error.

- 3) **Print format**——Peripheral parameters can be set by print format of 24 or 32 formats. Besides by peripherals parameters printing language is Chinese or English.

6.5.1 Auto Print

In printing mode, the parameters of the communication automatically print ON/OFF is set to open. So after each weighing is completed, controller automatically prints the weighing result of this times. the format as follow:

English 24 print formats are as follows:

Batching list	
Unit: kg	
Recipe Number: 1	
Supplement number	Result
1	5.27
2	2.26
.	
.	
.	
11	3.35
12	2.56

English 32 print formats are as follows:

Batching list		
Unit: kg		
Recipe Number: 1		
Supplement number	target value	Result
1	5.00	5.27
2	2.00	2.26
.		
.		
.		
11	3.00	3.35
12	2.00	2.56

6.5.2 Cumulative print the recipe

In printing mode, stop, click **[Statistic]** on the main interface. Enter the recipe ACUM interface,click **[Data Edit]** to chose print all recipe ACUM data. Format is as follows:

English 24 print formats are as follows:

All recipe ACUM list
 Time: 2020/12/01 01:02
 Unit: kg

Recipe Number:	1
Times:	3
Weight:	105.34

Recipe Number:	2
Times:	0
Weight:	0.00

.
.
.

Recipe Number:	20
Times:	0
Weight:	0.00

English 32 print formats are as follows:

All recipe ACUM list
 Time: 2020/12/01 01:02
 Unit: kg

Recipe number:	1
Times:	3
Weight:	105.34

Supplement number:	2
Times:	0
Weight:	0.00

.
.
.

Supplement number:	20
Times:	0
Weight:	0

6.5.3 All Supplement ACUM Print

In printing mode, stop, click **[Statistic]** on the main interface. Enter the supplement ACUM interface,click **[Data Edit]** to chose print all supplement ACUM data . Format is as follows:

English 24 print formats are as follows:

All supplement ACUM list
 Time: 2020/12/01 01:02
 Unit: kg

 Supplement number: 1
 Times: 3
 Weight: 16.04

Supplement number: 2
 Times: 3
 Weight: 7.54

.
 .
 .

 Supplement number: 12
 Times: 3
 Weight: 7.65

English 32 print formats are as follows:

All supplement ACUM list

Time: 2020/12/01 01:02

Unit: kg

 Supplement number: 1
 Times: 3
 Weight: 16.04

Supplement number: 1
 Times: 3
 Weight: 16.04

.
 .
 .

Supplement number: 12
 Times: 3
 Weight: 7.65

6.6 Modbus-RTU protocol

The communication mode selected in serial port 1 or serial port 2 is Modbus-RTU.

6.6.1 Function code and abnormal code

◆ Controller function codes supported:

function code	name	Explanation
03	Read register	Up to 125 single read registers
06	Write Single Register	Use this function code to write a single register
10	Write Multiple	The controller supports a write command is only

	Registers	double register, the address must be aligned, not allowed writing only a portion of the double register is written, allowing read-only portion read out.
01	Read coil	Note that this is the bit length units
05	Write coil	

Note: The controller only supports MODBUS function code above, will not be the controller response function code to other controllers.

◆ MODBUS exception code in response to

Code	Name	Explanation
02	Illegal Data Address	For this controller, the data representing the address of the error code is an address not allowed.
03	Illegal data value	And writing the data portion of the permitted range.
04	Slave failure	When the controller is attempting to perform the requested operation, resulting in unrecoverable error.
07	Unsuccessful programming request	For controllers, the the received command can not be executed under the current conditions.

6.6.2 MODBUS transmission mode

The transmission mode is MODBUS RTU mode.

When communication with the RTU mode, information of each 8-bit byte is divided into two 4-bit transmission character hexadecimal.

Data Format: **8** Data bits, **1**Stop bit, even parity (**8-E-1**)

8 Data bits, **1**Stop bits, no parity (**8-N-1**)

Baud rate: **9600/19200/38400/57600/115200**(Choose one)

Code: RTU

6.6.3 MODBUS address assignment

Protocol address	PLC address	Meaning	Description
Stature information parameters, below contents are read only register (function codes 0x03)			
0000-0001	40001-40002	current display weight	current display weight
0002-0003	40003-40004	reserved	
0004	40005	Weight state sign	D13-D15: reserved
			D12 : Gross/Net weight: 0. Gross weight: 1. Net weight
			D11: Calculate the weight using the theoretical value (prompt the user when

			calculating the weight using the theoretical value)
			D9~10: reserved
			D8: Million volt stability, (mark of million volt stability in calibration)
			D7: Loadcell Under, below the allowable range of Loadcell voltage
			D6: Loadcell Over, over the allowable range of Loadcell voltage
			D5: weight under, weight < “-(full range+9d)”
			D4: weight over, weight > “ full range+9d”
			D3: OFLstate, (weight or load cell abnormal)
			D2: display weight -, (display weight negative)
			D1: zero, (weight is in 0 ± 1/4d range)
			D0: stable, (A stable mark of weight stability)
0005	40006	Error code 1 (calibration)	D10-D15 reserved
			D12: full range write in failure
			D11: gain calibration success
			D10: ZERO Calibration Done
			D09: Calibration Failed-Over Min. Resolution (Each of the indices is less than 0.1uV)
			D08: Calibration Failed-Weight Input Error

			D07: Calibration Failed-Weight Input Error
			D06: Calibration Failed-Gain Voltage Under Zero or previous calibration point
			D05: Calibration Failed-Gain Voltage Over
			D04: Calibration Failed-Gain Voltage Under
			D03: Calibration Failed-Loadcell Not Stable
			D02: Calibration Failed-Zero Voltage Over
			D01: Calibration Failed-Gain Voltage Under
			D00: Calibration Failed-Loadcell Not Stable
0006	40007	Error code 2 (zero and tare operation error)	D6-D15 reserved
			D05: zero load cell over
			D04: zero load cell under
			D03: zero instable
			D02: zero over range
			D01 : power on zeroing instable
			D00 : power on zeroing over range
0007~0009	4008~40010	reserved	
0010	40011	Process state flag bit 1, Display in order of filling state	D12-D15: reserved
			D11: Supplement 12th of Recipe filling
			D10: Supplement 11th of Recipe filling
			D09: Supplement 10th of Recipe filling
			D08: Supplement 9th of

			Recipe filling
			D07: Supplement 8th of Recipe filling
			D06: Supplement 7th of Recipe filling
			D05: Supplement 6th of Recipe filling
			D04: Supplement 5th of Recipe filling
			D03: Supplement 4th of Recipe filling
			D02: Supplement 3rd of Recipe filling
			D01: Supplement 2nd of Recipe filling
			D00: Supplement 1st of Recipe filling
0011	40012	Process state flag bit 2, Display in order of filling state	D12-D15: reserved
			D11: 12th tank filling
			D10: 11 th tank filling
			D09: 10 th tank filling
			D08: 9 th tank filling
			D07: 8 th tank filling
			D06: 7 th tank filling
			D05: 6 th tank filling
			D04: 5 th tank filling
			D03: 4 th tank filling
			D02: 3 rd tank filling
			D01: 2 nd tank filling
D00: 1 st tank filling			
0012	40013	Process state flag bit 3, Display in order of filling state	D15: Done
			D14: DICS
			D13: BATCH PAUSE
			D12: STIR
			D11 : Supplement filling

			done
			D10: Auto Compensation
			D09: Qualified (the state is closed after DICS)
			D08: UNDER pause (No pause, no alarm, then the state will be closed after DICS. If there is a clear alarm action, it will be closed after the clear alarm)
			D07: OVER pause (No pause, no alarm, then the state will be closed after DICS. If there is a clear alarm action, it will be closed after the clear alarm)
			D06: over/under detecting
			D05: reserved
			D04: value wait
			D03: fi-fill
			D02: me-fill
			D01: co-fill
			D00: pre-fill
			D15: batch complete
0014	40015	Process state flag bit 4, other state display areas	D04-D15: add as needed
			D03: DICS allow level
			D02: clear supplement
			D01: alarm
			D00: pause
0015~0017	40016~40018	reserved	
GS, NT, GS address (read only)			
0018	40019	GS Hi-Lo	GS value, have signal, INT

0019	40020	GS Lo-Hi	
0020	40021	NT Hi-Lo	NT value, have signal, INT
0021	40022	NT Lo-Hi	
0022	40023	Tare value Hi-Lo	Tare value, have signal, INT
0023	40024	Tare value Lo-Hi	
0024~0025	40025~40026	reserved	
0026	40027	display weight Hi-Lo	current display weight, have signal, floating-point type
0027	40028	display weight Lo-Hi	
0028	40029	Tare Hi-Lo	GS value, have signal, floating-point type
0029	40030	Tare Lo-Hi	
0030	40031	Nt Hi-Lo	NT value, have signal, floating-point type
0031	40032	Nt Lo-Hi	
0032	40033	Tare Hi-Lo	Tare value, have signal, floating-point type
0033	40034	Tare Lo-Hi	
0034~0035	40035~40036	reserved	
Load cell voltage, relative zero voltage (read only)			
0036	40037	Filter AD code	Filter ADC code bipolar –data with signal; unipolar-data without signal
0037	40038	Load cell voltage	Data with signal, integer, four digit point
0038	40039	Load cell voltage	
0039	40040	Relative zero voltage	Data with signal, integer, four digit point
0040	40041	Relative zero voltage	
0041~0081	40042~40082	reserved	
Total ACUM Times, Total ACUM Weight address (Read only)			
0082	40083	Total ACUM Times Hi-Lo	ACUM Times
0083	40084	Total ACUM Times Hi-Lo	
0084	40085	Total ACUM Times Lo-Hi	
0085	40086	Total ACUM Times Lo-Hi	

0086	40087	Total ACUM Weight Hi-Lo	Total ACUM Weight
0087	40088	Total ACUM Weight Hi-Lo	
0088	40089	Total ACUM Weight Lo-Hi	
0089	40090	Total ACUM Weight Lo-Hi	
0090	40091	reserved	
I/O Function state display address (Read only)			
0091	40092	Input state area	D12-D15 reserved
			D11: Input 12 state
			D10: Input 11 state
			D9: Input 10 state
			D8: Input 9 state
			D7: Input 8 state
			D6: Input 7 state
			D5: Input 6 state
			D4: Input 5 state
			D3: Input 4 state
			D2: Input 3 state
			D1: Input 2 state
D0: Input 1 state			
0092	40093	reserved	
0093	40094	Output state area	D15: Output 16 state
			D14: Output 15 state
			D13: Output 14 state
			D12: Output 13 state
			D11: Output 12 state
			D10: Output 11 state
			D9: Output 10 state
			D8: Output 9 state
D7: Output 8 state			
D6: Output 7 state			

			D5: Output 6 state
			D4: Output 5 state
			D3: Output 4 state
			D2: Output 3 state
			D1: Output 2 state
			D0: Output 1 state
0094~0099	40095~40100	reserved	
Weighing parameter, Readable and writable register (Write function code 0x06 , read function code 0x03)			
0100-0101	40101-40102	PWR-ON Zero	Initial value: 20% ; range: full range 0%-99%
0102~0103	40103~40104	reserved	
0104-0105	40105-40106	Zero Range	Initial value: 50% ; range: full range 1%-99%
0106~0113	40107~40114	reserved	
0114-0115	40115-40116	STAB Range	Initial value: 2 ; Parameter range: 0-99d
0116-0117	40117-40118	STAB Time	Initial value: 0.3s ; Parameter range: 0.1-9.9s
0118-0119	40119-40120	TrZero Range	Initial value: 0 ; Parameter range: 0-9d
0120-0121	40121-40122	TrZero Time	Initial value: 2.0s ; Parameter range: 1-99.9s
0122-0123	40123-40124	D-Filter Strength	Initial value: 5 ; Parameter range: 0-9
0124-0125	40125-40126	Vib-Filter	Initial value: OFF ; Parameter range: ON/OFF
0126-0127	40127-40128	AD sampling frequency	Initial value: 2 ; Parameter range: 0: 120; 1: 240; 2: 480; 3: 960
Calibrate parameter, Readable and writable register (Write function code 0x06 , read function code 0x03)			
0200-0201	40201-40202	Unit	Initial value: 1 ; 0 — g, 1 — kg, 2 — t, 3 — lb(pound)
0202-0203	40203-40204	Decimal point	Initial value: 2 ;

			Optional: 0—0; 1—0.0; 2—0.00; 3—0.000; 4—0.0000.
0204-0205	40205-40206	Division	Initial value: 1; Optional: (1/ 2/ 5/ 10/ 20/ 50/100/200/500)。
0206-0207	40207-40208	Full range	Initial value: 10000; Write range (full range \leq Minimum Division \times 100000, \leq 999999)
0208	40209	reserved	
0210-0211	40211-40210	Calibration Zero	Write 1 when the current weight as the zero point, the weight of the scale platform is stable to allow writing; Returns the current zero millivolt on read.
0212-0213	40211-40212	Cal ZERO By Valtage	The written data is used as the zero voltage value. Write data integer type, but the system regard that the data has a 4-digit decimal, read the current zero voltage
0214-0215	40215-40216	Calibration Weight	Input standard weight (\leq full range); Readout is the current load cell relative to zero millivolt
0216~0223	40217~40224	reserved	
0224-0225	40225-40226	Key In Loadcells Average Sensitive	Write the actual sensitivity of the load cell used for the theoretical value calibration
0226-0227	40227-40228	Key In Loadcells Total Capacity	Write the total capacity of the load cell for the theoretical calibration

0228-0229	40229-40230	Theoretical Calibration In Use	Write 1 use the theoretical value calibration, write 0 use the calibration data.
0230-0231	40231-40232	Weight Correct Coefficient/WT Correct	Write the coefficient to modify the calibration, write the data integer type, the system default data write data with 5 decimal point.
0232~0299	40233~40300	reserved	
Recipe parameter, Readable and writable register (Write function code 0x06 , read function code 0x03)			
0300-0301	40301-40302	Recipe ID	Initial value: 1; Parameter range: 1~20
0302-0303	40303-40304	Supplement type quantity	Initial value: 12; Parameter range: 0~12 If the sum of the unclosed sequence of supplements below does not equal to this data, it will not be allowed to run and alarm.
0304-0305	40305-40306	The tank number of the 1st kind of supplement in the recipe	Initial value: 1; Parameter range: 0~12. 0 is skipped, and 1~12 denotes the jar number for filling.
0306-0307	40307-40308	The tank number of the 2nd kind of supplement in the recipe	
0308-0309	40309-40310	The tank number of the 3rd kind of supplement in the recipe	
0310-0311	40311-40312	The tank number of the 4th kind of supplement in the recipe	
0312-0313	40313-40314	The tank number of the 5th kind of supplement in the recipe	
0314-0315	40315-40316	The tank number of the 6th kind of supplement in	

		the recipe	
0316-0317	40317-40318	The tank number of the 7th kind of supplement in the recipe	
0318-0319	40319-40320	The tank number of the 8th kind of supplement in the recipe	
0320-0321	40321-40322	The tank number of the 9th kind of supplement in the recipe	
0322-0323	40323-40324	The tank number of the 10th kind of supplement in the recipe	
0324-0325	40325-40326	The tank number of the 11th kind of supplement in the recipe	
0326-0327	40327-40328	The tank number of the 12th kind of supplement in the recipe	
0328-0329	40329-0330	Batch times	Initial value: 0; Parameter range: 0~9999
0330-0331	0331-0332	Number of remaining batches	Ready only
0332~0339	40333~40341	reserved	
0340-0341	40341-40342	No.1 supplement target value	Note: The write value value should \leq full range.
0342-0343	40343-40344	No.1 supplement Co-Fill Remain	
0344-0345	40345-40346	No.1 supplement Me-Fill Remain	
0346-0347	40347-40348	No.1 supplement Free Fall value	
0348-0349	40349-40350	No.1 supplement OVER value	
0350-0351	40351-40352	No.1 supplement UNDER value	
0352-0353	40353-40354	No.1 supplement Filling	

		PreDelay Timer	
0354-0355	40355-40356	No.1 supplement COMP.Inhibit Timer(Co-F)	
0356-0357	40357-40358	No.1 supplement COMP.Inhibit Timer(Me-F)	
0358-0359	40359-40360	No.1 supplement COMP.Inhibit Timer(Fi-F)	
0360-0361	40361-40362	No.1 supplement Pause mode	
0362-0363	40363-40364	No.1 supplement Stir mode	
0364-0365	40365-40366	No.1 supplement Stir PreDelay	
0366-0367	40367-40368	No.1 supplement Stir Time	
0368-0369	40369-40370	No.1 supplement Delay After Stir	
0370~0379	40371~40380	reserved	
0380~0419	40381~40420	No.2 supplement recipe contents	sequence as above
0420~0459	40421~40460	No.3 supplement recipe contents	sequence as above
0460~0499	40461~40500	No.4 supplement recipe contents	sequence as above
0500~0539	40501~40540	No.5 supplement recipe contents	sequence as above
0540~0579	40541~40580	No.6 supplement recipe contents	sequence as above
0580~0619	40581~40620	No.7 supplement recipe contents	sequence as above
0620~0659	40621~40660	No.8 supplement recipe contents	sequence as above

0660~0699	40661~40700	No.9 supplement recipe contents	sequence as above
0700~0739	40701~40740	No.10 supplement recipe contents	sequence as above
0740~0779	40741~40780	No.11 supplement recipe contents	sequence as above
0780~0819	40781~40820	No.12 supplement recipe contents	sequence as above
0820-0821	40821-40822	Power Loss Resume	Initial value: OFF; Parameter range: OFF/ON
0822-0823	40823-40824	Continuous Batching ON/OFF	Initial value: OFF; Parameter range: OFF/ON
0824-0825	40825-40826	Weight Prepare For Fill	Initial value: OFF; Parameter range : OFF/ZERO, TARE
0826-0827	40827-40828	Tare Range Control ON/OFF	Initial value: OFF; Parameter range: OFF/ON
0828-0829	40829-40830	Tare Up Limit	Initial value: 0; Parameter range: 0~999999
0830-0831	40831-40832	Tare Low Limit	Initial value: 0; Parameter range: 0~999999
0832-0833	40833-40834	Fill Speed Control	Initial value: 0- Combination; Parameter range: 0- Combination, 1- Sequence, 2- Optimized
0834-0835	40835-40836	Pause Time (Co-F → Me-F)	Initial value: 0; Parameter range: 0~999
0836-0837	40837-40838	Pause Time (Me-F → Fi-F)	Initial value: 0; Parameter range: 0~999
0838-0839	40839-40840	JogFlow ON/OFF	Initial value: OFF; range: OFF/ON
0840-0841	40841-40842	JogFlow ON Timer	Initial value: 5; range: 0~999
0842-0843	40843-40844	JogFlow OFF Timer	Initial value: 5; range: 0~999
0844-0845	40845-40846	Free fall correction	Initial value: 1; range: 0~99

		Reference Samples PCS	
0846-0847	40847-40848	Free fall correction Effective Range	Initial value: 2; range: 0~99
0848-0849	40849-40850	Free fall correction Percentage	Initial value: 1; range: 0~2
0850-0851	40851-40852	Result Waiting Timer	Initial value: 5; range: 0~999
0852-0853	40853-4854	OVER/UNDER Check	Initial value: OFF; range: OFF/ON
0854-0855	40855-40856	OVER/UNDER Pause	Initial value: OFF; range: OFF/ON
0856-0857	40857-40858	OVER/UNDER Alarm Timer	Initial value: 5; range: 0~999
0858-0859	40859-40860	Compensation Times	Initial value: 3; range: 0~99
0860-0861	40861-40862	Fill-ON Timer	Initial value: 5; range: 0~999
0862-0863	40863-40864	Fill-OFF Timer	Initial value: 5; range: 0~999
0864-0865	40865-40866	DISC mode option	Initial value: 0; DISC after all batching complete 1:Discharge after each feeding
0866-0867	40867-40868	DISC Control	Initial value: OFF; range: OFF/ON
0868-0869	40869-40870	Near Zero Band	Initial value: 0; range: 0~999999
0870-0871	40871-40872	DISC Delay Timer	Initial value: 5; range: 0~999
0872-0873	40873-40874	DISC Monitor Time	Initial value: 0; range: 0~999
0874-0875	40875-40876	Batching Monitor Time	Initial value: 0; range: 0~999
0876~0877	40877~40878	reserved	
0878-0879	40879-40880	Current supplement No.	ready only
0880-0881	40881-40882	Gross Sign Correction	Initial value: OFF; range: OFF/ON
0882-0883	40883-40884	Peripheral mixer	Initial value: OFF; range:

			OFF/ON
0884-0885	40885-40886	Peripheral stirring timer	Initial value: 5; range: 0~999
0886-0887	40887-40888	DISC timer	Initial value: 5; range: 0~999
0888-0889	40889-40890	Delay after DISC	Initial value: 5; range: 0~999
0890-0891	40891-40892	STAB Prepare For Changing	Initial value: OFF; option: ON/OFF
0892~4989	40893~44900	reserved	
All supplement ACUM weight, below parameter ready only			
4900-4903	44901-44904	The ACUM weight of the current recipe supplement 1	ready only
4904-4907	44905-44908	The ACUM weight of the current recipe supplement 2	ready only
4908-4911	44909-44912	The ACUM weight of the current recipe supplement 3	ready only
4912-4915	44913-44916	The ACUM weight of the current recipe supplement 4	ready only
4916~4919	44917~44920	The ACUM weight of the current recipe supplement 5	ready only
4920-4923	44921-44924	The ACUM weight of the current recipe supplement 6	ready only
4924-4927	44925-44928	The ACUM weight of the current recipe supplement 7	ready only
4928-4931	44929-44932	The ACUM weight of the current recipe supplement 8	ready only
4932-4935	44933-44936	The ACUM weight of the current recipe supplement 9	ready only
4936-4939	44937-44940	The ACUM weight of the current recipe supplement 10	ready only
4940-4943	44941-44944	The ACUM weight of the current recipe supplement 11	ready only
4944-4947	44945-44948	The ACUM weight of the current recipe supplement 12	ready only
4948-4949	44949-44950	The actual batch value of this supplement 1	ready only

4950-4951	44951-44952	The actual batch value of this supplement 2	ready only
4952-4953	44953-44954	The actual batch value of this supplement 3	ready only
4954-4955	44955-44956	The actual batch value of this supplement 4	ready only
4956-4957	44957-44958	The actual batch value of this supplement 5	ready only
4958-4959	44959-44960	The actual batch value of this supplement 6	ready only
4960-4961	44961-44962	The actual batch value of this supplement 7	ready only
4962-4963	44963-44964	The actual batch value of this supplement 8	ready only
4964-4965	44965-44966	The actual batch value of this supplement 9	ready only
4966-4967	44967-44968	The actual batch value of this supplement 10	ready only
4968-4969	44969-44970	The actual batch value of this supplement 11	ready only
4970-4971	44971-44972	The actual batch value of this supplement 12	ready only
4972-4973	44973-44974	Clear recipe ACUM	Write 1-20 to clear the Recipe ID ACUM; Write 100 to Clear Choose Recipe ACUM; Write 101 to Clear All Recipe ACUM.
4974-4999	44975-45000	reserved	
ACUM parameter, ready only register (read function code 0x03)			
5000-5001	45001-45002	1 recipe supplement 1 ACUM weight HI-LO	ready only
5002-5003	45003-45004	1 recipe supplement 1 ACUM weight LO-HI	ready only
5004-5005	45005-45006	1 recipe supplement 1 ACUM times	ready only
5006-5007	45007-45008	1 recipe supplement 2	ready only

		ACUM weight HI-LO	
5008-5009	45009-45010	1 recipe supplement 2 ACUM weight LO-HI	ready only
5010-5011	45011-45012	1 recipe supplement 2 ACUM times	ready only
5012-5013	45003-45014	1 recipe supplement 3 ACUM weight HI-LO	ready only
5014-5015	45015-45016	1 recipe supplement 3 ACUM weight LO-HI	ready only
5016-5017	45017-45018	1 recipe supplement 3 ACUM times	ready only
5018-5019	45019-45020	1 recipe supplement 4 ACUM weight HI-LO	ready only
5020-5021	45021-45022	1 recipe supplement 4 ACUM weight LO-HI	ready only
5022-5023	45023-45024	1 recipe supplement 4 ACUM times	ready only
5024-5025	45025-45026	1 recipe supplement 5 ACUM weight HI-LO	ready only
5026-5027	45027-45028	1 recipe supplement 5 ACUM weight LO-HI	ready only
5028-5029	45029-45030	1 recipe supplement 5 ACUM times	ready only
5030-5031	45031-45032	1 recipe supplement 6 ACUM weight HI-LO	ready only
5032-5033	45033-45034	1 recipe supplement 6 ACUM weight LO-HI	ready only
5034-5035	45035-45036	1 recipe supplement 6 ACUM times	ready only
5036-5037	45037-45038	1 recipe supplement 7 ACUM weight HI-LO	ready only
5038-5039	45039-45040	1 recipe supplement 7 ACUM weight LO-HI	ready only
5040-5041	45041-45042	1 recipe supplement 7 ACUM times	ready only
5042-5043	45043-45044	1 recipe supplement 8 ACUM weight HI-LO	ready only

5044-5045	45045-45046	1 recipe supplement 8 ACUM weight LO-HI	ready only
5046-5047	45047-45048	1 recipe supplement 8 ACUM times	ready only
5048-5049	45049-45050	1 recipe supplement 9 ACUM weight HI-LO	ready only
5050-5051	45051-45052	1 recipe supplement 9 ACUM weight LO-HI	ready only
5052-5053	45053-45054	1 recipe supplement 9 ACUM times	ready only
5054-5055	45055-45056	1 recipe supplement 10 ACUM weight HI-LO	ready only
5056-5057	45057-45058	1 recipe supplement 10 ACUM weight LO-HI	ready only
5058-5059	45059-45060	1 recipe supplement 10 ACUM times	ready only
5060-5061	45061-45062	1 recipe supplement 11 ACUM weight HI-LO	ready only
5062-5063	45063-45064	1 recipe supplement 11 ACUM weight LO-HI	ready only
5064-5065	45065-45066	1 recipe supplement 11 ACUM times	ready only
5066-5067	45067-45068	1 recipe supplement 12 ACUM weight HI-LO	ready only
5068-5069	45069-45070	1 recipe supplement 12 ACUM weight LO-HI	ready only
5070-5071	45071-45072	1 recipe supplement 12 ACUM times	ready only
5072-5073	45073-45074	1 recipe total ACUM weight	ready only
5074-5075	45075-45076	1 recipe total ACUM times	ready only
5076~5099	45077~45100	reserved	
5100-5199	45101-45200	2 recipe ACUM data	ready only
5200-5299	45201-45300	3 recipe ACUM data	ready only
5300-5399	45301-45400	4 recipe ACUM data	ready only
5400-5499	45401-45500	5 recipe ACUM data	ready only
5500-5599	45501-45600	6 recipe ACUM data	ready only

5600-5699	45601-45700	7 recipe ACUM data	ready only
5700-5799	45701-45800	8 recipe ACUM data	ready only
5800-5899	45801-45900	9 recipe ACUM data	ready only
5900-5999	45901-46000	10 recipe ACUM data	ready only
6000-6099	46001-46100	11 recipe ACUM data	ready only
6100-6199	46101-46200	12 recipe ACUM data	ready only
6200-6299	46201-46300	13 recipe ACUM data	ready only
6300-6399	46301-46400	14 recipe ACUM data	ready only
6400-6499	46401-46500	15 recipe ACUM data	ready only
6500-6599	46501-46600	16 recipe ACUM data	ready only
6600-6699	46601-46700	17 recipe ACUM data	ready only
6700-6799	46701-46800	18 recipe ACUM data	ready only
6800-6899	46801-46900	19 recipe ACUM data	ready only
6900-6999	46901-47000	20 recipe ACUM data	ready only
IO parameter , Readable and writable register (Write function code 0x06 , read function code 0x03)			
7000-7001	47001-47002	Input 1 function	IO input function define: 0: no define; 1: start; 2: stop; 3: E-Stop; 4: pause; 5: ZERO; 6: clear alarm; 7: Change Recipe; 8: M-Disc/DISC Permission; 9: TARE; 10: Clear tare; 11: Start/Stop; 12: Manual Stir 13: Allow release 14: Print All Supplement ACUM Data 15: Print All Recipe ACUM Data
7002-7003	47003-47004	Input 2 function	
7004-7005	47005-47006	Input 3 function	
7006-7007	47007-47008	Input 4 function	
7008-7009	47009-47010	Input 5 function	
7010-7011	47011-47012	Input 6 function	
7012-7013	47013-47014	Input 7 function	
7014-7015	47015-47016	Input 8 function	
7016-7017	47017-47018	Input 9 function	
7018-7019	47019-47020	Input 10 function	
7020-7021	47021-47022	Input 11 function	
7022-7023	47023-47024	Input 12 function	
7024~7099	47025~47100	reserved	

7100-7101	47101-47102	Output 1 function	IO output function define: 0: no define; 1: Running; 2: stop; 3: Co-Fill; 4: Me-Fill; 5: Fi-Fill; 6: 1st Supplement; 7: 2nd Supplement; 8: 3rd Supplement; 9: 4th Supplement; 10: 5th Supplement; 11: 6th Supplement; 12: 7th Supplement; 13: 8th Supplement; 14: 9th Supplement; 15: 10th Supplement; 16: 11th Supplement; 17: 12th Supplement; 18: Result Waiting 19: Over/Under; 20: Over; 21: Under; 22: DICS; 23: NearZero; 24: STAB; 25: Alarm; 26: Batch Complete; 27: pause; 28: Batch Done 29: DICS Done; 30: Stir; 31: OFL; 32: ZERO Failed; 33: Blender Release
7102-7103	47103-47104	Output 2 function	
7104-7105	47105-47106	Output 3 function	
7106-7107	47107-47108	Output 4 function	
7108-7109	47109-47110	Output 5 function	
7110-7111	47111-47112	Output 6 function	
7112-7113	47113-47114	Output 7 function	
7114-7115	47115-47116	Output 8 function	
7116-7117	47117-47118	Output 9 function	
7118-7119	47119-47120	Output 10 function	
7120-7121	47121-47122	Output 11 function	
7122-7123	47123-47124	Output 12 function	
7124-7125	47125-47126	Output 13 function	
7126-7127	47127-47128	Output 14 function	
7128-7129	47129-47130	Output 15 function	
7130-7131	47131-47132	Output 16 function	
7132~7999	47133~48000	reserved	
Communication parameter, Readable and writable register (Write function code 0x06, read function code 0x03)			

8000	48001	485COM ID	Initial value: 1 ; 1~99 option
8001	48002	Baudrate	0: 9600; 1: 19200; 2: 38400; 3: 57600; 4: 115200
8002	48003	Protocol	0: Modbus-RTU ; 1: rE-Cont; 2: rE-Read; 3: tt; 4: rS-Cont; 5: rS-Read; 6: Print;
8003	48004	Data Format	Communication data format option. (data bit, check bit, stop bit. E : even check; N : no check) 0: 8-E-1; 1: 8-N-1; 2: 7-E-1; 3: 7-N-1
8004	48005	Modbus Dword Format	Initial value: 0: AB-CD; range: 0-1 0: AB-CD; 1: CD – AB
8005	48006	Send Interval	Continuous mode automatically sends time intervals, unit ms Initial value: 50 ; 0~1000 option
8006	48007	Send ChecksumONOFF	tt (Toledo continuous mode)protocol Send Checksum or not 0: don't Send Checksum; 1: Send Checksum
8007~8019	48008~48020	reserved	
8020	48021	232COM ID	Initial value: 1 ; 1~99 option
8021	48022	Baudrate	0: 9600;

			1: 19200; 2: 38400; 3: 57600; 4: 115200
8022	48023	Protocol	0: Modbus-RTU ; 1: rE-Cont; 2: rE-Read; 3: tt; 4: rS-Cont; 5: rS-Read; 6: Print;
8023	48024	Data Format	Communication data format option. (data bit, check bit, stop bit. E: even check; N: no check) 0: 8-E-1; 1: 8-N-1; 2: 7-E-1; 3: 7-N-1.
8024	48025	ModbusDword Format	Initial value: 0: AB-CD; range: 0-1 0: AB-CD; 1: CD – AB
8025	48026	Continuous Send Interval	Continuous mode automatically sends time intervals, unit ms Initial value: 50; 0~1000 option
8026	48027	Send ChecksumONOFF	tt (Toledo continuous mode)protocol Send Checksum or not 0: don't Send Checksum; 1: Send Checksum
8027~8099	48028~48100	reserved	
8100	48101	Protocol	Modbus-TCP
8101	48102	Ethernet Dword Format	Initial value: 0: AB-CD; range: 0-1 0: AB-CD;

			1: CD - AB。
8102	48103	reserved	
8103	48104	IP1	default 192 , range 0~255
8104	48105	IP2	default 168 , range 0~255
8105	48106	IP3	default 101 , range 0~255
8106	48107	IP4	default 246 , range 0~255
8107~8149	48108~48150	reserved	
8150	48151	Auto print ON/OFF	Initial value: 0. 1: ON, 0: OFF
8151	48152	Print format	Initial value: 0 0: 24 lines 1: 32 lines
8152	48153	Print language	Initial value: 0.1: English: 0: Chinese
8153	48154	Print lines	Initial value: 3, 0-9
8154	48155	Print all recipe ACUM	Write 1 to print
8155	48156	Print all supplement ACUM	Write 1 to print
8156~8299	48157~48300	reserved	
IO Test			
8300	48301	IO test mode	Write: stop state can write in 1 start I/O Module test ; input 0 exit I/O Module test state (only in stop state can be revised) Read: 1 : I/O Module test state 0 : Non I/O Module test state
8301	48302	Input 1 test	Write: not allow write in Read: From Hi to lo respectively correspond IN1~12 input. 1 input valid, 0 input invalid.
8302	48303	Input 2 test	
8303	48304	Input 3 test	
8304	48305	Input 4 test	
8305	48306	Input 5 test	
8306	48307	Input 6 test	
8307	48308	Input 7 test	
8308	48309	Input 8 test	

8309	48310	Input 9 test	
8310	48311	Input 10 test	
8311	48312	Input 11 test	
8312	48313	Input 12 test	
8313~8349	48314~48350	reserved	
8350	48351	Input 1 test	Write: I/O Module test ,ON/OFF turn to ON can write, From Lo to Hi respectively correspond OUT1~16 output. 1 output valid, 0 output invalid. Read: exit current output, I/O Module port state, From Lo to Hi respectively correspond OUT1~16 output. 1 output valid, 0 output invalid.
8351	48352	Input 2 test	
8352	48353	Input 3 test	
8353	48354	Input 4 test	
8354	48355	Input 5 test	
8355	48356	Input 6 test	
8356	48357	Input 7 test	
8357	48358	Input 8 test	
8358	48359	Input 9 test	
8359	48360	Input 10 test	
8360	48361	Input 11 test	
8361	48362	Input 12 test	
8362	48363	Input 13 test	
8363	48364	Input 14 test	
8364	48365	Input 15 test	
8365	48366	Input 16 test	
8366~8599	48367~48600	reserved	
Running parameter, Readable and writable register (Write function code 0x06, read function code 0x03)			
8600	48601	ZERO	write non 0 can ZERO
8601	48602	TARE	write non 0 can TARE
8602	48603	Clear tare	write non 0 can Clear tare
8603	48604	reserved	
8604	48605	Quick zero	write non 0 can zero calibration
8605	48606	reserved	
8606	48607	start	write non 0 can start controller
8607	48608	E-Stop	write non 0 can E-Stop controller
8608	48609	to stop	write non 0 can to stop

			controller
8609	48610	pause (pulse)	write non 0 can pause controller
8610	48611	reserved	
8611	48612	reserved	
8612	48613	reserved	
8613	48614	clear alarm	write non 0 can clear Alarm
8614	48615	M-Disc/DISC Permission	write non 0 can DICS
8615	48616	Change recipe	write non 0 can change recipe (Write the recipe each time and add 1 in order)
8616	48617	Clear ACUM	write non 0 can clear total ACUM and ACUM times
8617	48618	Clear supplement 1	write non 0 can clear supplement 1
8618	48619	Clear supplement 2	write non 0 can clear supplement 2
8619	48620	Clear supplement 3	write non 0 can clear supplement 3
8620	48621	Clear supplement 4	write non 0 can clear supplement 4
8621	48622	Clear supplement 5	write non 0 can clear supplement 5
8622	48623	Clear supplement 6	write non 0 can clear supplement 6
8623	48624	Clear supplement 7	write non 0 can clear supplement 7
8624	48625	Clear supplement 8	write non 0 can clear supplement 8
8625	48626	Clear supplement 9	write non 0 can clear supplement 9
8626	48627	Clear supplement 10	write non 0 can clear supplement 10
8627	48628	Clear supplement 11	write non 0 can clear supplement 11

8628	48629	Clear supplement 12	write non 0 can clear supplement 12
8629	48630	Power off save recovery inquiry	power off save turn to ON, write non 0 can power off recovery
8630	48631	Stir	write non 0 can turn on Manual Stir
8631~8999	48632~49000	reserved	
Reset parameter, Readable and writable register (Write function code 0x06 , read function code 0x03)			
8900	48901	All	Write 1, read 0
8901	48902	part (all but do not include calibration)	
8902	48903	calibration parameter reset	
8903	48904	Weighing parameter reset (basic parameters of the transmitter class)	
8904	48905	All I/O function reset	
8905	48906	All communication parameter reset	
8906	48907	All recipe parameter reset	
8907	48908	All ACUM parameter reset	
8908~9999	48909~41000 0	reserved	
Software version etc ready only parameter			
10000	410001	version (Hi-Lo)	read only
10001	410002	version (Lo-Hi)	
10002	410003	Compile Date (Hi-Lo)	
10003	410004	Compile Date (Lo-Hi)	
10029	410030	reserved	
10004~10099	410005~410100	reserved	
10100	410101	Ethernet 0 controller Mac address 1, 0-255	read only

10101	410102	Ethernet 0 controller Mac address 2, 0-255	
10102	410103	Ethernet 0 controller Mac address 3, 0-255	
10103	410104	Ethernet 0 controller Mac address 4, 0-255	
10104	410105	Ethernet 0 controller Mac address 5, 0-255	
10105	410106	Ethernet 0 controller Mac address 6, 0-255	
10106~	410107~	reserved	
Coil address, Readable and writable coil (Write function code 0x05, read function code 0x01)			
0	1	ZERO	This address can only write 1. Read 0
1	2	TARE	
2	3	Clear tare	
3	4	reserved	
4	5	Quick zero	This address can only write 1. Read :valid=0001H; invalid=000H
5	6	reserved	
6	7	start	
7	8	E-Stop	
8	9	stop	
9	10	pause (pulse)	
10~12	11~13	reserved	
13	14	clear alarm	This address can only write 1. Read 0
14	15	M-Disc/DISC Permission	This address can only write 1. Read :valid=0001H; invalid=000H
15	16	Change recipe	This address can only write 1. Read 0
16	17	Clear ACUM	This address can only write 1. If the accumulative times is not 0,it is read as 1,otherwise it is 0
17	18	Clear supplement 1	Write 1 to clear supplement, read as 1;
18	19	Clear supplement 2	

19	20	Clear supplement 3	Write 0 ,close clearing supplement function, read as 0; (Note,only single supplement can be cleared)	
20	21	Clear supplement 4		
21	22	Clear supplement 5		
22	23	Clear supplement 6		
23	24	Clear supplement 7		
24	25	Clear supplement 8		
25	26	Clear supplement 9		
26	27	Clear supplement 10		
27	28	Clear supplement 11		
28	29	Clear supplement 12		
29	30	Power off save recovery inquiry		Read 1: Restore power? Write 1: recovery; Write 0: no recovery
30	31	Stir		This address can only write 1. Read :valid=0001H; invalid=000H
31~299	32~300	reserved		
300	301	Input 1 state	read only	
301	302	Input 2 state		
302	303	Input 3 state		
303	304	Input 4 state		
304	305	Input 5 state		
305	306	Input 6 state		
306	307	Input 7 state		
307	308	Input 8 state		
308	309	Input 9 state		
309	310	Input 10 state		
310	311	Input 11 state		
311	312	Input 12 state		
312~349	313~350	reserved		
350	351	Output 1 state	read only	
351	352	Output 2 state		
352	353	Output 3 state		
353	354	Output 4 state		
354	355	Output 5 state		
355	356	Output 6 state		

356	357	Output 7 state	
357	358	Output 8 state	
358	359	Output 9 state	
359	360	Output 10 state	
360	361	Output 11 state	
361	362	Output 12 state	
362	363	Output 13 state	
363	364	Output 14 state	
364	365	Output 15 state	
365	366	Output 16 state	
366~	367~	reserved	

7. Auto batching process

Before the automatic batching operation, user needs to configure the related parameter in the batching process. After the configuration is complete, the automatic batching process will proceed according to the user-defined configuration.

7.1 Auto batching sequence

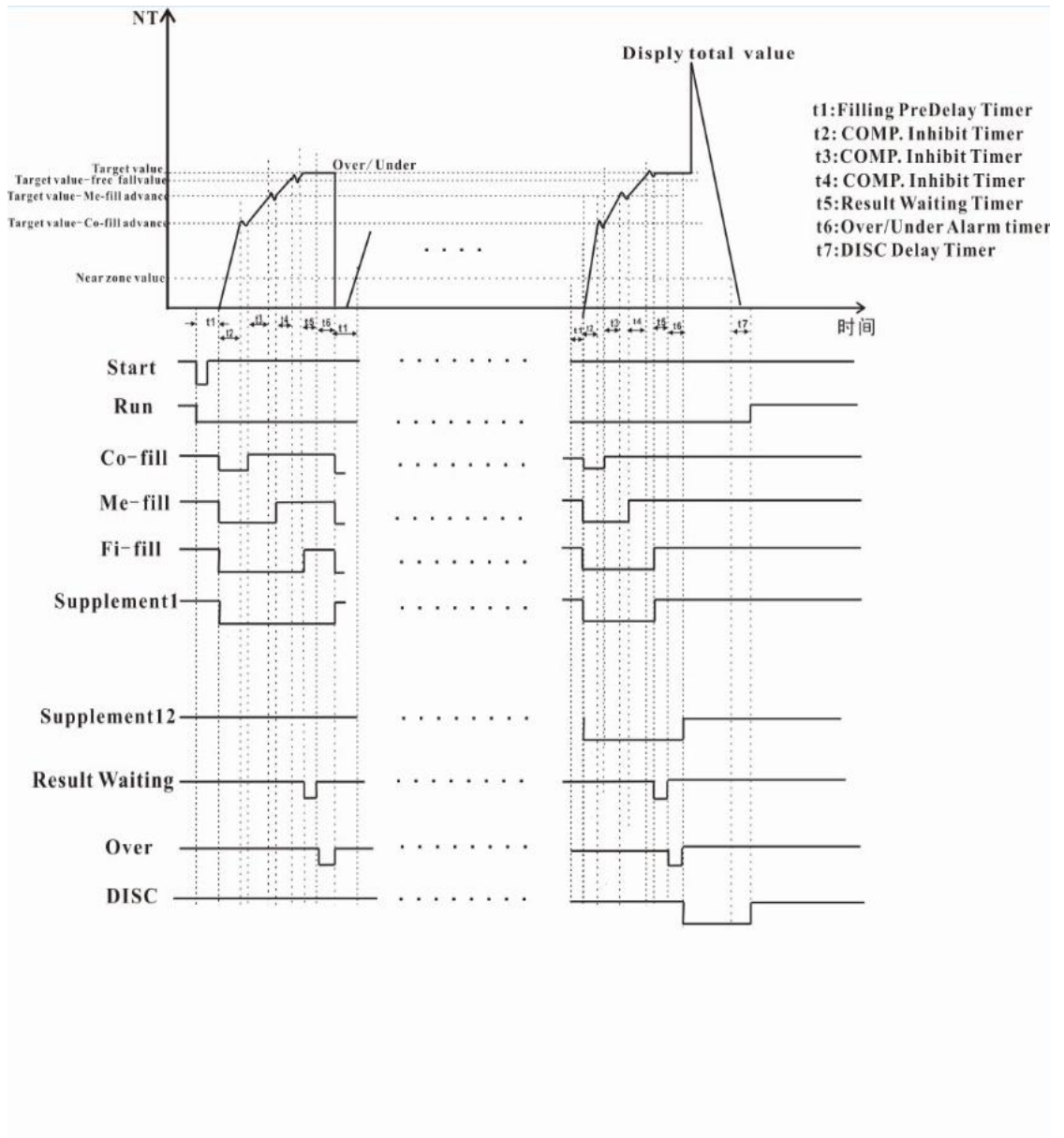

7.2 Basic process description:

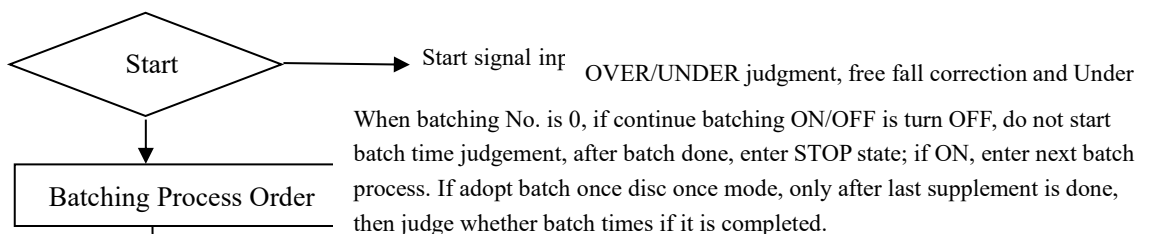

8. Dimension (mm)

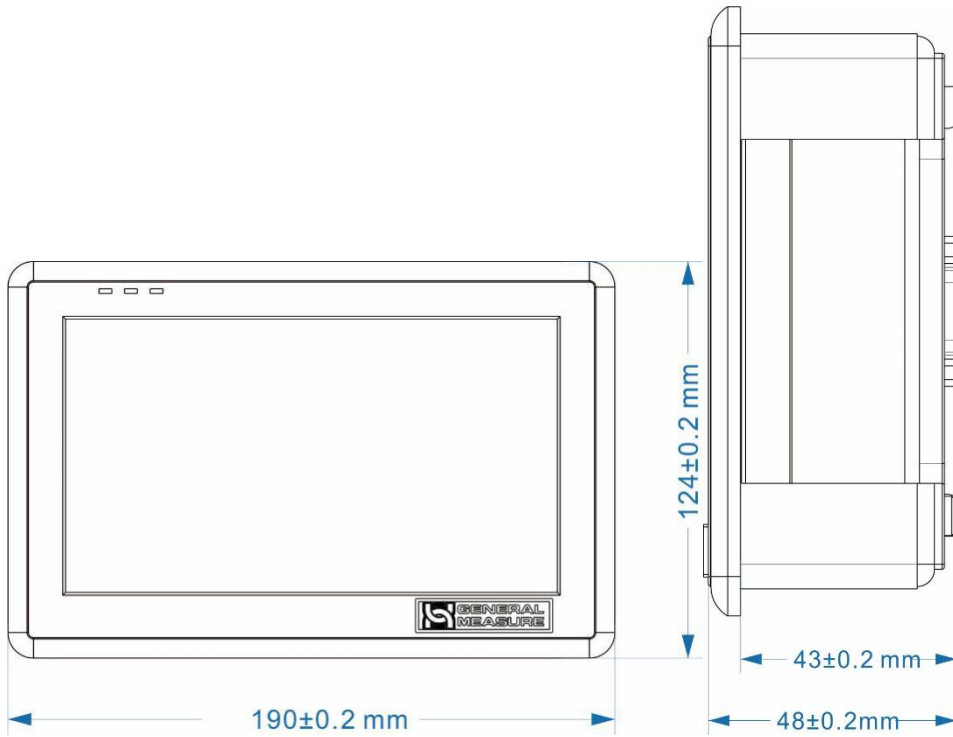

ON hole size

